



Fourier Optics Course

with corrected exercises

Eric Aristidi

Revision date: February 28, 2025

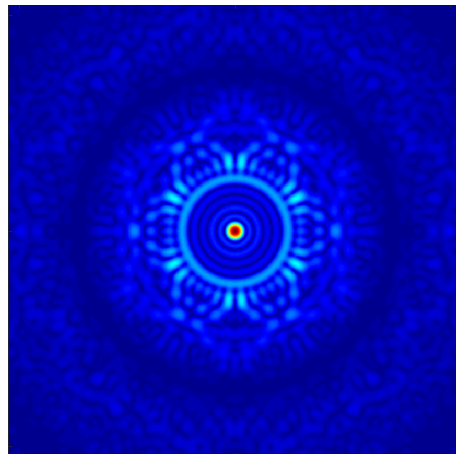

Simulation of the Point-Spread Function of a 39 pupils interferometer, with sub-apertures disposed on 3 concentric rings.

Contents

0	Reminders about Fourier analysis	3
0.1	Some useful functions	3
0.1.1	The rectangular function	3
0.1.2	Dirac delta distribution	4
0.1.3	Dirac comb	5
0.2	Convolution	6
0.2.1	Definition	6
0.2.2	Properties	6
0.3	Fourier transform	8
0.3.1	Definition	8
0.3.2	Properties	9
0.3.3	Table of Fourier transforms	10
1	Reminders about diffraction	11
1.1	Some particular kinds of waves	11
1.1.1	Monochromatic waves	11
1.1.2	Plane waves	11
1.1.3	Spherical waves	12
1.2	Huyghens-Fresnel principle	15
1.2.1	Introduction	15
1.2.2	Paraxial approximation and Fresnel diffraction	15
1.2.3	A proof of the Huyghens-Fresnel relation in paraxial approximation	16
1.2.4	Far field: Fraunhofer diffraction	17
1.2.5	Example of Fraunhofer diffraction patterns	18
1.2.6	Diffraction gratings	20
2	Fourier properties of converging lenses	27
2.1	Phase screens	27
2.1.1	Transmission coefficient of a thin phase screen	27
2.1.2	Example: prism	28
2.1.3	Converging lens	28
2.2	Converging lenses and Fourier transform	29
2.2.1	Object in the same plane as the lens	29
2.2.2	Object at the front focal plane	30
3	Coherent optical filtering	32
3.1	Principle	32
3.2	Abbe-Porter experiments	32
3.3	Object-image relation	34
3.4	Low-pass and high-pass filters	35
3.4.1	Low-pass filters	35
3.4.2	High-pass filters	37
3.5	Strioscopy and phase contrast	37
3.5.1	Strioscopy	38
3.5.2	Phase contrast	39

4	Image formation	40
4.1	Object-image convolution relation	40
4.1.1	Image created by a point-source	40
4.1.2	Object-image relation	42
4.2	Optical transfer function (OTF)	43
4.3	Case of a circular pupil	45
4.3.1	PSF and resolving power	45
4.3.2	Optical transfer function	46
5	Exercises	48
0	Exercises for chapter 0	48
0.1	1-dim Fourier transforms	48
0.2	2-dim Fourier transforms	48
1	Exercises for chapter 1	49
1.1	Fresnel diffraction of elementary waves	49
1.2	Fresnel diffraction of of a periodic pattern — Talbot effect	49
1.3	Fresnel diffraction by a circular aperture	49
1.4	The Moon laser at the Plateau de Calern	50
1.5	Aperture synthesis	50
1.6	Circular pupil with central obstruction	51
1.7	Fraunhofer diffraction by a screen	51
1.8	Fraunhofer diffraction by a 2D periodic pattern	51
1.9	Bright filament	52
2	Exercises for chapter 2	53
2.1	Measuring the focal length of a telescope	53
2.2	Focusing screens	53
2.3	Diffraction grating	54
2.4	Cylindrical lens	54
2.5	Apodized grating	55
2.6	Lens lit by a point-source	55
3	Exercises for chapter 3	56
3.1	Filtering of periodic patterns	56
3.2	High-pass optical filtering	57
3.3	Image replication	57
3.4	Optical filtering with coherent and incoherent light	58
3.5	Optical filtering by a pair of holes	59
3.6	Coherent optical filtering	59
3.7	Phase contrast	60
4	Exercises for chapter 4	61
4.1	Image of a double star and pupil apodization	61
4.2	Measurement of the angular diameter of a star	61
4.3	Image of a sinusoidal grid	62
4.4	Diluted pupil with two circular apertures	62
4.5	Study of a defocus aberration	62
4.6	Rectangular pupil with phase shift	63
4.7	A simple pistonscope	64
4.8	Circular disc with limb darkening	64
4.9	Circumstellar ring	65
4.10	3 apertures interferometer	66
	Appendix: Solutions to exercises	67

Chapter 0

Reminders about Fourier analysis

Also read:

- Bracewell, R. “The Fourier Transform and its applications”
- Goodman, J.W. “Introduction to Fourier Optics”, chap 2
- Roddier, F., “Distributions et transformation de Fourier” (in french)

0.1 Some useful functions

0.1.1 The rectangular function

The rectangular function (or *rectangle function*, or *gate function*) is useful to describe objects like slits or diaphragms whose transmission is 0 or 1. It is defined as

$$\begin{aligned} \Pi(x) &= 1 \text{ if } |x| < \frac{1}{2} \\ \Pi(x) &= 0 \text{ otherwise} \end{aligned} \tag{1}$$

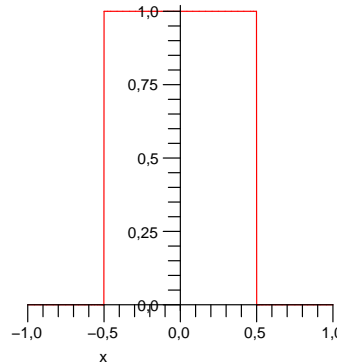

Some other definitions may be found in the literature (in particular for the value at $x = \pm\frac{1}{2}$). A rectangular function of width a centered at $x = b$ will express as $\Pi\left(\frac{x-b}{a}\right)$.

2D rectangle function

We consider functions of 2 variables x and y . The quantity

$$f(x, y) = \Pi(x) = \Pi(x) \mathbf{1}(y)$$

describes a strip of width 1 parallel to the y axis : it is invariant by translation along y (see Fig. 1). The notation $\mathbf{1}(y)$ stands for a function which value is 1 whatever y .

A two dimensional gate function of width a in the x direction and b in the y direction expresses as

$$f(x, y) = \Pi\left(\frac{x}{a}\right) \Pi\left(\frac{y}{b}\right) \tag{2}$$

We shall use this function throughout this course to express the transmission coefficient of rectangular slits.

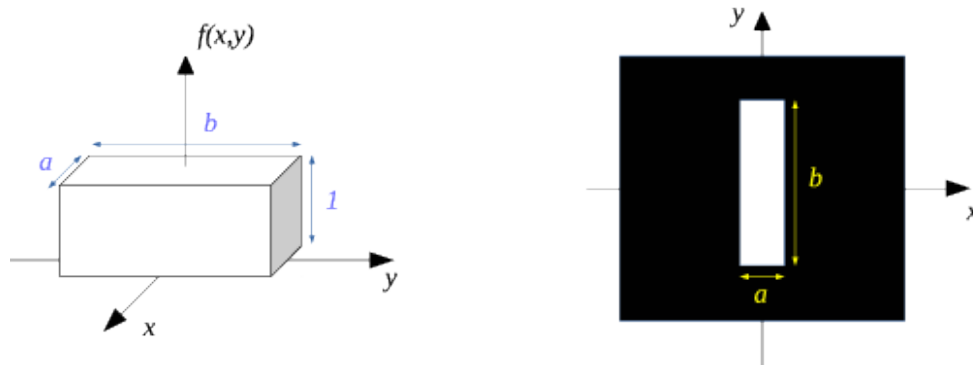

Figure 1: 2D rectangle function $f(x, y) = \Pi\left(\frac{x}{a}\right) \Pi\left(\frac{y}{b}\right)$ of width a in the x direction and b in the y . Left: perspective plot as a function of x and y . Right: gray-level representation in the (x, y) plane.

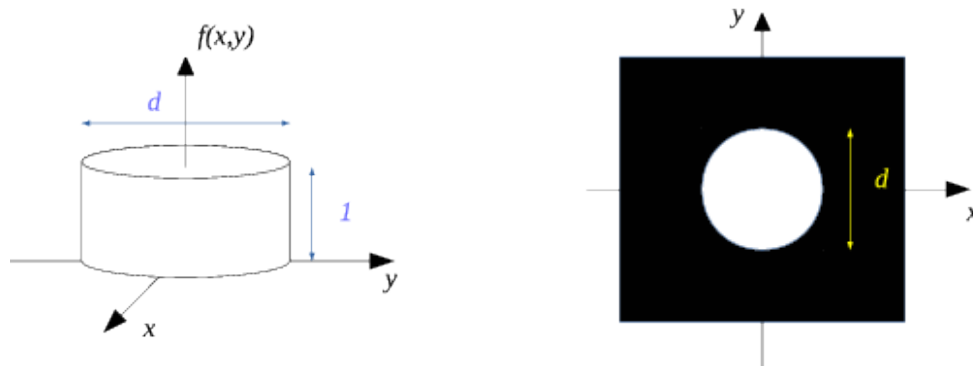

Figure 2: 2D circular function $f(x, y) = \Pi\left(\frac{\rho}{d}\right)$ of diameter d . Left: perspective plot as a function of x and y . Right: gray-level representation in the (x, y) plane.

2D circular function

We consider the following quantity:

$$f(x, y) = \Pi\left(\frac{\rho}{d}\right) \quad (3)$$

with $\rho = \sqrt{x^2 + y^2}$. Its value is one for $\rho < \frac{d}{2}$, i.e. inside a disc of diameter d . This function will be used to describe transmission coefficient of circular diaphragms.

0.1.2 Dirac delta distribution

The Dirac delta distribution (also known as “Dirac impulse”) $\delta(x)$ can be defined as a function which is 0 if $x \neq 0$ and infinite for $x = 0$. Its integral is 1:

$$\int_{-\infty}^{\infty} \delta(x) dx = 1 \quad (4)$$

and this last relation shows that $\delta(x)$ has the dimension of $[x]^{-1}$. The δ distribution is often represented as a vertical arrow centered as $x = 0$, of height 1, as in the graph on the right.

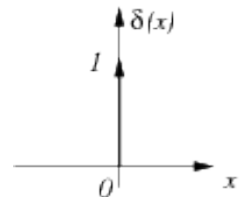

The Dirac δ is sometimes defined as the limit of a rectangular function of width $\epsilon \rightarrow 0$ and height $\frac{1}{\epsilon}$ so that its integral remains 1:

$$\delta(x) = \lim_{\epsilon \rightarrow 0} \frac{1}{\epsilon} \Pi\left(\frac{x}{\epsilon}\right) \quad (5)$$

An important property is:

$$f(x) \delta(x - a) = f(a) \delta(x - a) \quad (6)$$

where $\delta(x - a)$ is the Dirac impulse centered at $x = a$. Some other properties are:

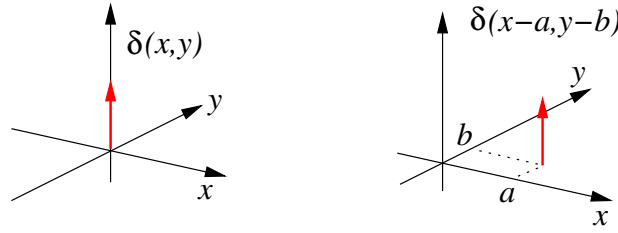

Figure 3: Graphic representation of the 2D Dirac impulses. Left: $\delta(x, y)$. Right: shifted impulse $\delta(x - a, y - b)$ centered at $x = a, y = b$.

- $\delta(ax) = \frac{1}{|a|} \delta(x)$ (for $a \neq 0$)
- $\delta(x) = \frac{d}{dx}H(x)$ where $H(x)$ is the Heaviside distribution (1 if $x > 0$, 0 if $x < 0$).

2D Dirac impulse

We define the 2D Dirac distribution as

$$\delta(x, y) = \delta(x) \cdot \delta(y) \quad (7)$$

It is 0 in the whole plane (x, y) excepted at the origin where it is infinite. Its integral is 1:

$$\iint_{-\infty}^{\infty} \delta(x, y) dx dy = 1 \quad (8)$$

The 2D Dirac impulse can be considered as the limit of a 2D rectangular function of width ϵ in both directions x and y (the area under the rectangular function being ϵ^2):

$$\delta(x, y) = \lim_{\epsilon \rightarrow 0} \frac{1}{\epsilon^2} \Pi\left(\frac{x}{\epsilon}\right) \Pi\left(\frac{y}{\epsilon}\right) \quad (9)$$

It is also the limit of a 2D circular function of diameter ϵ (and of surface $s = \pi \frac{\epsilon^2}{4}$)

$$\delta(x, y) = \lim_{\epsilon \rightarrow 0} \frac{1}{s} \Pi\left(\frac{\rho}{\epsilon}\right) \quad (10)$$

The 2D Dirac distribution is often used in optics to describe the amplitude of a point-source, or the transmission coefficient of a pin-hole (diaphragm with very small diameter).

0.1.3 Dirac comb

The Dirac comb is a periodic succession of Dirac impulses:

$$\text{III}(x) = \sum_{n=-\infty}^{\infty} \delta(x - n) \quad (11)$$

its period is 1 in the standart form above, its graph (on the right) looks like a comb, hence its name.

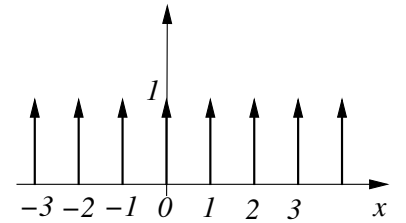

It is possible to define a comb of period a , having all δ impulses located at $x = na$ (n integer) as

$$\text{III}_a(x) = \sum_{n=-\infty}^{\infty} \delta(x - na) = \frac{1}{|a|} \text{III}\left(\frac{x}{a}\right) \quad (12)$$

The comb is of fundamental importance in signal processing: it is the tool used to describe mathematically the operation of sampling. In optics it is used to describe periodic structures such as diffraction gratings.

2D Dirac comb

The 2D Dirac comb (sometimes denoted as “Dirac brush”) is the product of 2 combs in directions x and y :

$$\text{III}_a(x) \cdot \text{III}_b(y) = \sum_{n=-\infty}^{\infty} \sum_{p=-\infty}^{\infty} \delta(x - na, y - pb) \quad (13)$$

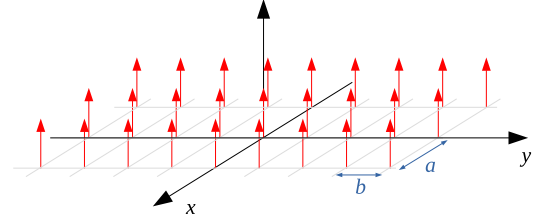

with a and b the periods in x and y directions.

0.2 Convolution

0.2.1 Definition

The convolution product of two functions f and g is defined as

$$h(x) = (f * g)(x) = \int_{-\infty}^{\infty} f(x')g(x - x')dx' \quad (14)$$

It can be interpreted as a weighted moving average of the function f ($g(-x)$ being the weighting function). In signal processing, g is denoted as “impulse response”. If g is a function such as a Gaussian or a rectangle, the convolution will result into a smoothing of the details of f .

2D convolution

The 2D convolution between two functions of (x, y) is

$$h(x, y) = (f * g)(x, y) = \iint_{-\infty}^{\infty} f(x', y')g(x - x', y - y')dx' dy' \quad (15)$$

Note that we use the same symbol $*$ for 1D and 2D convolutions, but the two operations are different (single integral for 1D, double integral for 2D). The 2D impulse response is sometimes denoted as “point-spread function”. The 2D convolution has a lot of applications in image processing; for example convolving an image $f(x, y)$ by a 2D rectangle function will blur the image.

0.2.2 Properties

Here are some properties of the convolution:

- It is commutative ($f * g = g * f$) and associative ($f * (g * h) = (f * g) * h$)
- The convolution by $\mathbf{1}$ gives the integral of the function: $f(x) * \mathbf{1}(x) = \int f(x)dx$ (this can be useful for certain types of calculations).
- dilation: $(f * g)(\lambda x) = |\lambda|f(\lambda x) * g(\lambda x)$
- Convolving by $\delta(x)$ has no effect ($f(x) * \delta(x) = f(x)$). This property is the origin of the term “impulse response” for g in the relation $(f * g)$.
- Convolving by a shifted impulse $\delta(x - a)$ translates the function: $f(x) * \delta(x - a) = f(x - a)$. This property is very important and useful for Fourier optics calculations.
- Convolution by a comb:

$$f(x) * \text{III}_a(x) = \sum_{n=-\infty}^{\infty} f(x - na) \quad (16)$$

this is a *periodization* of the function f (each impulse of the comb is replaced by f , see Fig. 4).

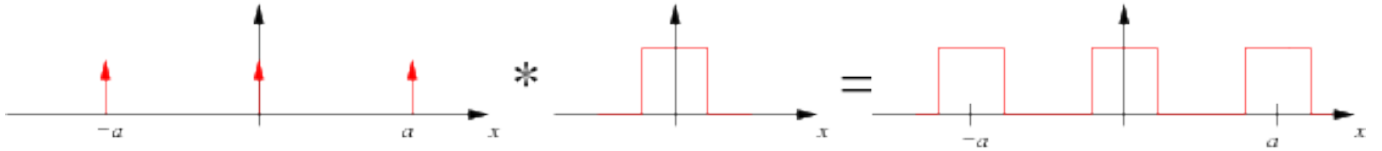

Figure 4: The convolution of a function f by a comb results into a periodization of f (Eq 16). Left, the comb of period a . Center: the function f (here a rectangular function). Right: result of the convolution.

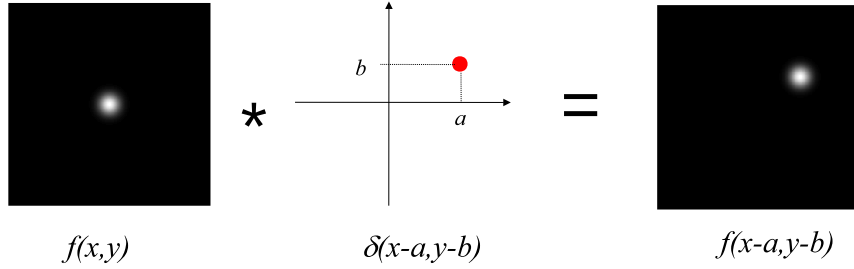

Figure 5: Property of translation of the convolution (Eq. 17): a function $f(x, y)$ (on the left) centered at the origin is convolved by a Dirac impulse centered at $(x = a, y = b)$. The result (on the right) is the shifted function $f(x - a, y - b)$ centered at $(x = a, y = b)$.

2D convolution

Most of the above properties apply to 2D convolution. In particular this one:

$$f(x, y) * \delta(x - a, y - b) = f(x - a, y - b) \tag{17}$$

which is illustrated by the Figure 5. A translation of a function inside the (x, y) plane can be expressed as a convolution by a shifted 2D Dirac impulse. This is the origin of the name “point-spread function” (PSF) for the impulse response at 2D (a 2D Dirac impulse is a infinitely sharp point in the (x, y) plane, and the convolution transforms this point into a larger function f).

A corollar of this property is:

$$f(x, y) * \sum_n A_n \delta(x - x_n, y - y_n) = \sum_n A_n f(x - x_n, y - y_n) \tag{18}$$

which is illustrated by Figs. 6 and 7.

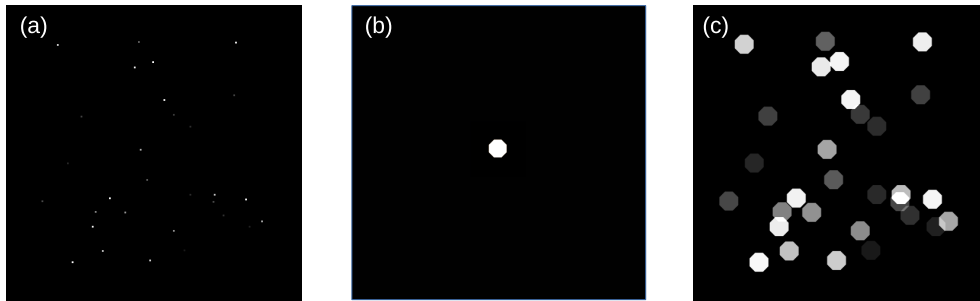

Figure 6: Illustration of Eq. 18. (a) gray-scale plot of a sum of 2D Dirac impulses with different amplitudes. (b) gray-scale plot of the point-spread function $f(x, y)$ ($f(x, y) = 1$ inside an octogonal domain, 0 elsewhere). (c) result of the 2D convolution of the two functions. As predicted by Eq. 18, the result is a sum of shifted PSFs (each impulse of the sum is replaced by the PSF, with the same amplitude A_n) When PSFs overlap, the result is the sum of overlapping terms.

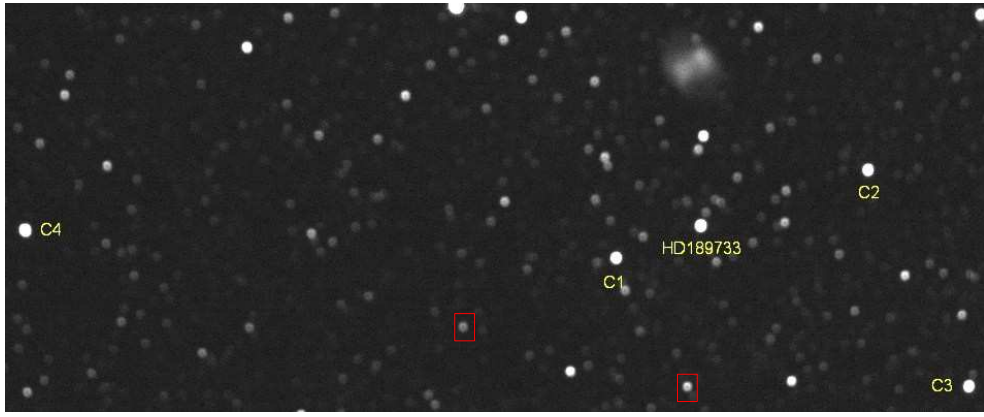

Figure 7: Image of portion of sky with a defocused optics: each star has the shape of a small disc, with a central obstruction. This is a typical illustration of a 2D convolution as in Fig. 7. The perfect image $f(x, y)$ is composed of a sum of 2D impulses (ideal image of a point-source). It is convolved by a Point-Spread function $g(x, y)$ which is the small disc (two examples are in the red boxes). The fuzzy object on the top right is the Dumbbell nebula, which is also convolved by the PSF (so that every point of the nebula is replaced by the PSF, resulting in a blurred image).

0.3 Fourier transform

0.3.1 Definition

The Fourier transform of a function $f(x)$ is defined as

$$\hat{f}(u) = \int_{-\infty}^{\infty} f(x) e^{-2i\pi ux} dx \quad (19)$$

it can be noted as $\hat{f}(u)$ or $\mathcal{F}[f]$. It is sometimes denoted as *frequency spectrum*, since it comes from the idea that a function can be developed as a weighted sum of complex sinusoids. The value $\hat{f}(u)$ represents the weight of the sinusoid of frequency u in the sum.

If x is a length, the variable u is a spatial frequency, having the dimension of $[x]^{-1}$. The spatial frequency of a space-dependent sinusoidal function (for ex. $\cos(2\pi ux)$) plays the same role as the temporal frequency for a time-dependent function, it represents the number of periods per unit of length. The dimension of $\hat{f}(u)$ is

$$[\hat{f}(u)] = [f].[x] \quad (20)$$

A very important property is

$$\mathcal{F}[\exp(2i\pi u_0 x)] = \delta(u - u_0) \quad (21)$$

i.e. the Fourier transform of a complex sinusoid of frequency u_0 is a Dirac impulse centered at u_0 . This emphasizes the fact that the complex sinusoid has only one frequency in its spectrum.

The inverse Fourier transform is

$$f(x) = \int_{-\infty}^{\infty} \hat{f}(u) e^{+2i\pi ux} du = \mathcal{F}^{-1}[\hat{f}] \quad (22)$$

2D Fourier transform

The 2D Fourier transform of a function of two variables $f(x, y)$ is defined as

$$\hat{f}(u, v) = \iint_{-\infty}^{\infty} f(x, y) e^{-2i\pi(ux+vy)} dx dy \quad (23)$$

The variables u and v are spatial frequencies associated to the space variables x and y . They define, in the (u, v) plane, a “spatial frequency vector” $\vec{\sigma} = \begin{vmatrix} u \\ v \end{vmatrix}$ (see Fig. 8). As for the 1D Fourier transform, the idea is that a function $f(x, y)$ can be expressed as a sum of 2D complex sinusoids of any period and any orientation.

The 2D inverse Fourier transform is

$$f(x, y) = \iint_{-\infty}^{\infty} \hat{f}(u, v) e^{+2i\pi(ux+vy)} dx dy \quad (24)$$

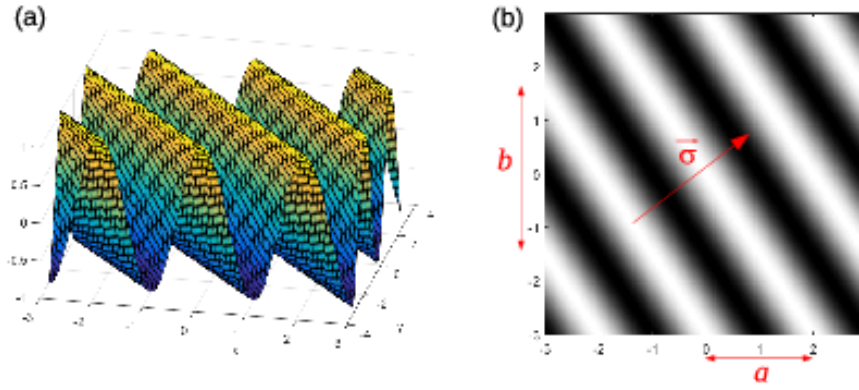

Figure 8: Representation of a 2D sinusoidal function $f(x, y) = \cos(2\pi\vec{\sigma}\cdot\vec{\rho}) = \cos(2\pi(ux + vy))$. (a): perspective plot. (b): grayscale plot. The frequency vector $\vec{\sigma} = (u, v)$ has been drawn on the right plot; it is perpendicular to the ridge lines of the function, its modulus is the frequency of the oscillations measured along the unit vector $\hat{\sigma}$. Its components are $u = \frac{1}{a}, v = \frac{1}{b}$ with a and b the periods in the x and y directions.

0.3.2 Properties

Here is a short list of useful properties of the 1D Fourier transform

- dilation: a function which is large in the direct plane will be narrow in the Fourier plane

$$f\left(\frac{x}{a}\right) \xrightarrow{\mathcal{F}} |a| \hat{f}(au) \quad (25)$$

- Convolution and product:

$$f(x) \cdot g(x) \xrightarrow{\mathcal{F}} \hat{f}(u) * \hat{g}(u)$$

$$f(x) * g(x) \xrightarrow{\mathcal{F}} \hat{f}(u) \cdot \hat{g}(u) \quad (26)$$

- Derivation: the Fourier transform of the derivative of a function is a high-pass filtering in the frequency plane (product by u which strengthens the high frequencies)

$$\frac{df}{dx} \xrightarrow{\mathcal{F}} 2i\pi u \hat{f}(u)$$

$$x \cdot f(x) \xrightarrow{\mathcal{F}} -\frac{1}{2i\pi} \frac{d\hat{f}}{du} \quad (27)$$

- Value at frequency $u = 0$: it is the integral of the function (this property is sometimes interesting to calculate integrals)

$$\hat{f}(0) = \int_{-\infty}^{\infty} f(x) dx \quad (28)$$

- Sign change for the variable x :

$$f(-x) \xrightarrow{\mathcal{F}} \hat{f}(-u) \quad (29)$$

- Complex conjugate:

$$\overline{f(x)} \xrightarrow{\mathcal{F}} \overline{\hat{f}(-u)} \quad (30)$$

- Double Fourier transform:

$$f(x) \xrightarrow{\mathcal{F}} \hat{f}(u) \xrightarrow{\mathcal{F}} f(-x) \quad (\text{or: } \hat{\hat{f}}(x) = f(-x)) \quad (31)$$

- Fourier transform of real-valued functions: they are *Hermitian*, with an even real part and an odd imaginary part. It can be summarized by

$$\text{is } f(x) \text{ real, then } \overline{\hat{f}(u)} = \hat{f}(-u) \quad (32)$$

- Real/even functions: if a function f is real and even, then
 - Its Fourier transform is also real and even (no imaginary part)
 - Its inverse transform is equal to its direct transform: $\mathcal{F}^{-1}[f](u) = \mathcal{F}[f](u)$

- Parseval theorem:

$$\int_{-\infty}^{\infty} |\hat{f}(x)|^2 dx = \int_{-\infty}^{\infty} |\hat{f}(u)|^2 du \quad (33)$$

Specific properties for 2D Fourier transform

Separable functions: if a function $h(x, y)$ is the product of two functions of one variable $f(x)$ and $g(y)$, then its 2D Fourier transform is also a separable function, i.e.

$$h(x, y) = f(x) \cdot g(y) \xrightarrow{\mathcal{F}} \hat{h}(u, v) = \hat{f}(u) \cdot \hat{g}(v) \quad (34)$$

This property must not to be confused with the Fourier transform of a product of functions of the same variables (Eq. 26): here the variables for f and g are different, and the 2D transform is a double integral.

Radial functions of the type $f(x, y) = f(\rho)$ with $\rho = \sqrt{x^2 + y^2}$: the 2D Fourier transform $\hat{f}(u, v)$ is also a radial function $F(q)$ with $q = \sqrt{u^2 + v^2}$. It takes the following form known as *Hankel transform*:

$$F(q) = \hat{f}(u, v) = \int_0^{\infty} 2\pi\rho f(\rho) J_0(2\pi q\rho) d\rho \quad (35)$$

where $J_0(x)$ is the zero order Bessel function. The Hankel transform $f(\rho) \rightarrow F(q)$ is not to be confused with the 1D Fourier transform (Eq. 19).

0.3.3 Table of Fourier transforms

1D transforms

Function	Fourier transform	Function	Fourier transform
$\delta(x)$	$\mathbf{1}(u)$	$\mathbf{1}(x)$	$\delta(u)$
$\delta(x - a)$	$\exp(-2i\pi ua)$	$\exp(2i\pi mx)$	$\delta(u - m)$
Heaviside $H(x)$ <small>$H(x) = 1$ if $x > 0$, 0 otherwise</small>	$\frac{1}{2}\delta(u) + \text{VP}\left(\frac{1}{2i\pi u}\right)$	$\Pi\left(\frac{x}{a}\right)$	$ a \text{sinc}(\pi ua)$ <small>with $\text{sinc}(x) = \frac{\sin(x)}{x}$</small>
$\text{III}_a(t)$	$\text{III}(au)$	Triangle $\Lambda\left(\frac{x}{a}\right)$ <small>$\Lambda(x) = 1 - x$ if $x \leq 1$, 0 otherwise</small>	$ a \text{sinc}^2(\pi ua)$
$\cos(2\pi mx)$	$\frac{1}{2}\delta(u - m) + \frac{1}{2}\delta(u + m)$	$\sin(2\pi mx)$	$-\frac{1}{2}\delta(u - m) + \frac{1}{2}\delta(u + m)$
$\exp\left(-\left \frac{x}{a}\right \right)$	$\frac{2 a }{1 + 4\pi^2 a^2 u^2}$	$\frac{1}{1 + \left(\frac{x}{a}\right)^2}$	$\pi a \exp(-2\pi au)$
$\exp\left[-\pi\left(\frac{x}{a}\right)^2\right]$	$ a \exp(-\pi a^2 u^2)$	$\exp\left[i\pi\left(\frac{x}{a}\right)^2\right]$	$\sqrt{ia^2} \exp(-i\pi a^2 u^2)$

2D transforms (radial functions)

Function	Fourier transform	Function	Fourier transform
$\delta(\rho - a)$	$2\pi a J_0(2\pi a q)$	$\frac{1}{\sqrt{\rho^2 + a^2}}$	$\frac{\exp(-2\pi a q)}{q}$
$\Pi\left(\frac{\rho}{d}\right)$	$2S \text{jinc}(\pi d q)$ <small>$\text{jinc}(x) = \frac{J_1(x)}{x}$ $S = \frac{\pi d^2}{4}$</small>	$\text{大}\left(\frac{\rho}{d}\right)$ <small>$\text{大}(\rho) = \Pi(\rho) * \Pi(\rho)$</small>	$4S \text{jinc}(\pi d q)^2$
$\exp(-\pi\rho^2)$	$\exp(-\pi q^2)$	$\exp\left(i\pi\frac{\rho^2}{a^2}\right)$	$ia^2 \exp(-i\pi a^2 q^2)$

with $\rho = \sqrt{x^2 + y^2}$ and $q = \sqrt{u^2 + v^2}$

Chapter 1

Reminders about diffraction

Also read : Goodman, 'Introduction to Fourier Optics', chap. 3, 4

1.1 Some particular kinds of waves

1.1.1 Monochromatic waves

Electromagnetic waves are created by the propagation of an electromagnetic field (\vec{E}, \vec{B}) . Both are vectorial quantities, but the majority of diffraction phenomena can be explained by considering the scalar quantity $E(x, y, z, t)$ (either the electric or magnetic field, without vectors).

A monochromatic wave is characterised by a time dependence in $e^{-i\omega t}$. It has only **one pulsation** ω (with $\omega = 2\pi\nu$ where ν is the temporal frequency, typically 10^{15} Hz for visible light). It also has a unique wavelength $\lambda = \frac{c}{\nu}$ (or $\lambda = \frac{c}{n\nu}$ if the refraction index is n) whose dimension is a length (in m).

The field $E(x, y, z, t)$ takes the following form of a product of a spatial term and a temporal term:

$$E(x, y, z, t) = \psi(x, y, z) e^{-i\omega t} \quad (1.1)$$

where $\psi(x, y, z)$ (or $\psi(\vec{r})$), the spatial part of the field, is called the *complex amplitude* of the vibration. In what follows we will consider that all the waves are monochromatic, and will deal with complex amplitudes.

1.1.2 Plane waves

Wavefronts (i.e. surfaces where the electric field value is constant at a given time) are planes. The distance between two consecutive wavefronts is the wavelength λ (two consecutive wavefronts are characterized by a 2π phase difference between complex amplitudes in both planes).

We define the wave vector $\vec{k} = \frac{2\pi}{\lambda} \hat{k}$. Its norm is $\frac{2\pi}{\lambda}$ and its unit vector \hat{k} is parallel to the direction of propagation (see Fig. 1.1).

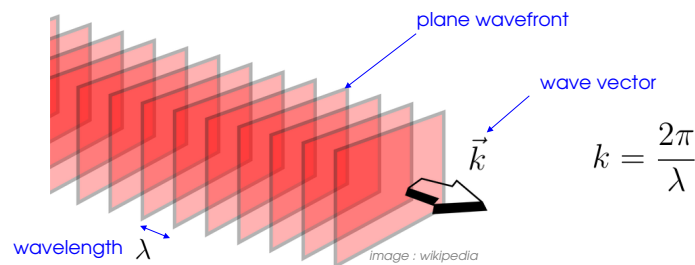

Figure 1.1: Structure of a plane wave

The electric field \vec{E} of a monochromatic plane wave takes the form

$$\vec{E} = \psi_0 e^{i(\vec{k}\cdot\vec{r}-\omega t)} \hat{E} \quad (1.2)$$

with ψ_0 a constant [unit: V/m] and \hat{E} a unit vector, perpendicular to \vec{k} . Note that \vec{E} is constant in a plane perpendicular to \vec{k} (i.e. plane waves are perpendicular to \vec{k} , see Fig. 1.1).

We denote as α , β and γ the three components of the unit vector \hat{k} (projections of \hat{k} onto the 3 axes as in the scheme on the right). The wave vector expresses as

$$\vec{k} = \frac{2\pi}{\lambda}(\alpha\hat{x} + \beta\hat{y} + \gamma\hat{z}) \quad (1.3)$$

with the condition $\sqrt{\alpha^2 + \beta^2 + \gamma^2} = 1$ (\hat{k} is a unit vector). The case ($\alpha = \beta = 0, \gamma = 1$) corresponds to a propagation parallel to the z axis.

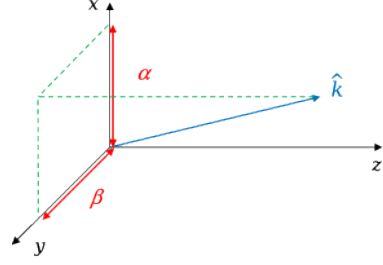

With these notations, the complex amplitude of a monochromatic plane wave takes the form

$$\psi(\vec{r}) = \psi_0 e^{i\vec{k}\cdot\vec{r}} = \psi_0 \exp\left[\frac{2i\pi}{\lambda}(\alpha x + \beta y + \gamma z)\right] \quad (1.4)$$

It exhibits a phase term which is a linear function of coordinates (x, y, z) .

Intensity It is the electromagnetic power per surface unit carried by the electromagnetic wave. It is proportional to the square modulus of the complex amplitude

$$I = (C^{te}) |\psi(\vec{r})|^2 \quad (1.5)$$

the multiplicative constant is generally taken as unity for a sake of simplicity.

1.1.3 Spherical waves

Wavefronts are concentric spheres (Fig. 1.2). If the center of these spheres is at the point $(0, 0, 0)$, the complex amplitude expresses as

$$\psi(\vec{r}) = \frac{S_0}{r} e^{ik\cdot r} \quad \text{or} \quad \psi(\vec{r}) = \frac{S_0}{r} e^{-ik\cdot r} \quad (1.6)$$

without vectors in the complex exponential. The sign $+$ (resp. $-$) denotes a diverging (resp. converging) spherical wave: the radius of the wave-spheres increase (resp decrease) with time. Note that

- The point $r = 0$ (center of the spheres) is singular, the field value diverges. It can be a *point-source* (case of a diverging wave) or a point of focalisation (converging wave).
- The dimension of S_0 is *not* that of an amplitude ($[S_0] = [\psi]\cdot[r]$, in V).

Case of a spherical wave not centered at the origin: if we call $\vec{r}_0 = (x_0, y_0, z_0)$ the center of wave-spheres, a simple translation allows to write the complex amplitude as:

$$\psi(\vec{r}) = \frac{S_0}{|\vec{r} - \vec{r}_0|} e^{\pm ik\cdot|\vec{r} - \vec{r}_0|} \quad (1.7)$$

with $|\vec{r} - \vec{r}_0| = \sqrt{(x - x_0)^2 + (y - y_0)^2 + (z - z_0)^2}$.

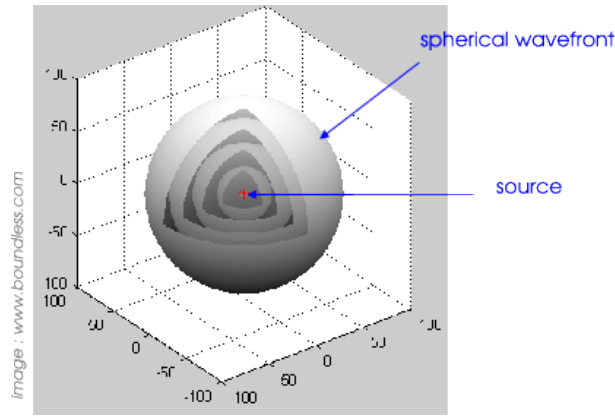
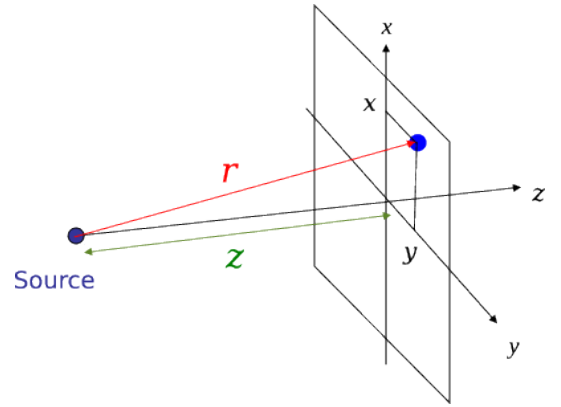

Figure 1.2: Structure of a spherical wave.

Paraxial approximation

It is an important approximation in Fourier optics, the majority of relations will be derived within this approximation. We consider that the segment joining the source and the point at \vec{r} is nearly parallel to the z -axis, as illustrated by the scheme on the right. If the source is at the origin, we have $|x| \ll |z|$ and $|y| \ll |z|$, and make the following approximation for r :

$$r \simeq |z| + \frac{\rho^2}{2|z|} \quad \text{with} \quad \rho^2 = x^2 + y^2 \quad (1.8)$$



The complex amplitude in paraxial approximation (if the source is at the origin) becomes

$$\psi(\vec{r}) \simeq \underbrace{\frac{S_0}{|z|} e^{\pm ik|z|}}_{\text{plane wave}} \cdot \underbrace{\exp\left(\pm \frac{i\pi\rho^2}{\lambda|z|}\right)}_{\text{phase curvature}} \quad (1.9)$$

It is the product of two terms

- A plane wave $\frac{S_0}{|z|} e^{\pm ik|z|}$ with wave-planes perpendicular to z ,
- A quadratic phase term $\exp\left(\pm \frac{i\pi\rho^2}{\lambda|z|}\right)$ which can be interpreted as a deviation from the plane wave. The wavefronts associated to this term are paraboloids (a paraboloid is indeed the 2nd order approximation of a sphere). This term is sometimes denoted as *phase curvature* because it is a pure phase term and in reference to the curvature of the wavefronts (see Fig. 1.3).

Plots of the paraxial form of the spherical wave amplitude are shown in Fig. 1.4. In a plane $z = C^{te}$, it is a centro-symmetric function whose real and imaginary part show concentric rings of characteristic size $\sqrt{\lambda z}$ (for $z > 0$).

For large z , the phase curvature vanishes and the spherical wave becomes plane. This happens when $|z| \gg \rho^2/\lambda$ (1m for $\lambda = 1\mu\text{m}$ and $\rho = 1\text{mm}$).

Validity of the approximation

The approximate expression for r in Eq. 1.8 is the leading terms of a Taylor expansion. The approximation is valid if the following term is small:

$$r \simeq |z| + \frac{\rho^2}{2|z|} + \frac{\rho^4}{8|z|^3} + \dots \quad (1.10)$$

The corresponding complex amplitude is

$$\psi(\vec{r}) \simeq \frac{S_0}{|z|} e^{\pm ik|z|} \exp\left(\pm \frac{i\pi\rho^2}{\lambda|z|}\right) \exp\left(\pm \frac{i\pi\rho^4}{4\lambda|z|^3}\right) \quad (1.11)$$

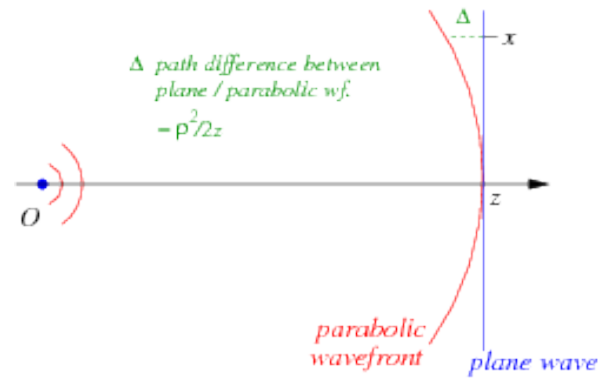

Figure 1.3: Paraxial approximation of a spherical wave, in the case of $z \gg \rho$. In this example, z is positive and the wave is diverging (+ sign in the complex exponentials). The spherical wave is the product of a plane wave under normal incidence (blue wave-plane) and a correcting term (phase curvature $e^{ik\Delta}$, red wavefront) as written in Eq. 1.9. The quantity $\Delta = \frac{\rho^2}{2z}$ is the path difference between blue and red wavefronts.

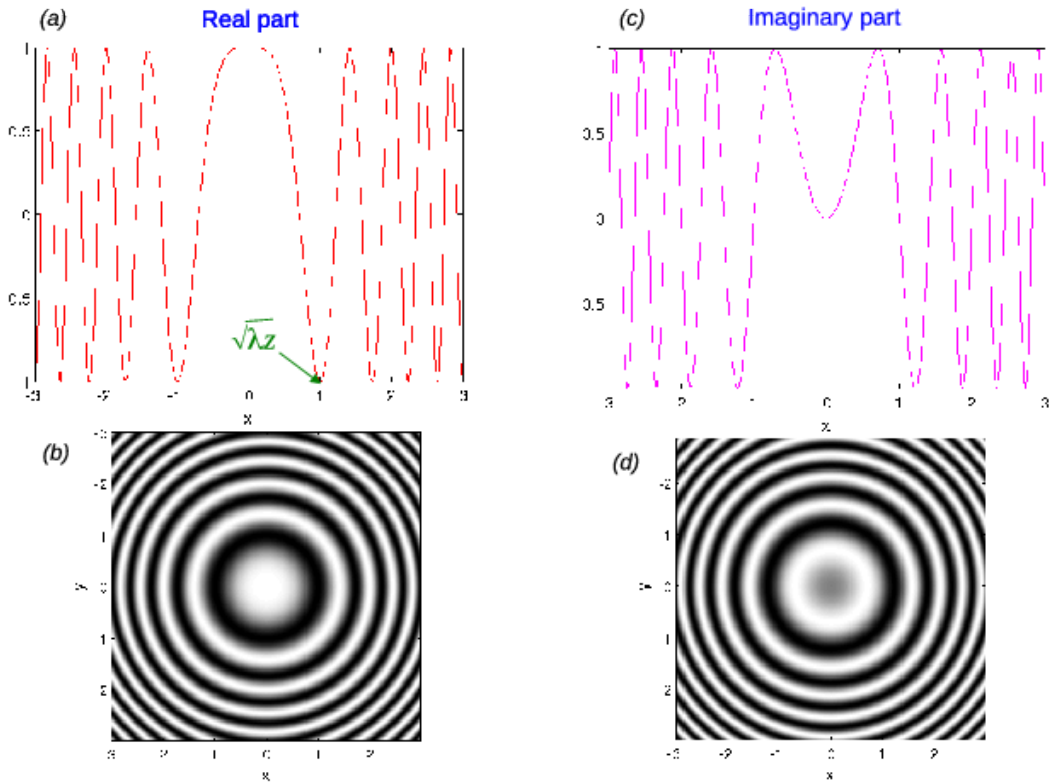

Figure 1.4: Plot of the complex amplitude $\psi(x, y, z) = C^{te} \exp\left(\frac{i\pi\rho^2}{\lambda z}\right)$ of a spherical wave in paraxial approximation for fixed z . (a) and (c): Real and imaginary parts as a function of ρ (in units of $\sqrt{\lambda z}$). (b) and (d): Grey-level plot of the real and imaginary parts in the (x, y) plane.

The paraxial approximation (Eq. 1.9) is valid if the last term is close to unity, i.e. if

$$|z| \gg \left(\frac{\rho^4}{\lambda}\right)^{\frac{1}{3}} \quad (1.12)$$

In visible light ($\lambda = 0.5\mu\text{m}$) and for $\rho=1\text{mm}$ this gives a few centimeters.

Case of a source at a position $\vec{r}_0 = (x_0, y_0, z_0)$: Making the variable change $x \rightarrow x - x_0$, $y \rightarrow y - y_0$, $z \rightarrow z - z_0$, we obtain

$$\psi(\vec{r}) \simeq \frac{S_0}{|z - z_0|} e^{\pm ik|z - z_0|} \exp\left(\pm \frac{i\pi[(x - x_0)^2 + (y - y_0)^2]}{\lambda|z - z_0|}\right) \quad (1.13)$$

1.2 Huyghens-Fresnel principle

Also read : Goodman, "Introduction to Fourier Optics", chap 4.

1.2.1 Introduction

The Huygens-Fresnel principle describes the way a monochromatic wave is modified when it propagates into space (this phenomenon is called *diffraction*). We shall consider a monochromatic wave of amplitude $f_0(x', y')$ in a plane taken as origin, $z = 0$. This can be obtained, for example, by placing a screen of transmission $t(x', y')$ (for example a slit or a diaphragm) in the path of a monochromatic plane wave of complex amplitude $\mathcal{A} = Ae^{ikz}$. In this case we simply have

$$f_0(x', y') = At(x', y') \quad (1.14)$$

The observation is made at in a plane a distance z from the plane $z = 0$, as in the scheme below. Note that we use the notations (x', y') for coordinates in the plane $z = 0$ and (x, y) in the observation plane. We suppose that the propagation is made towards $z > 0$, which will be assumed for the rest of this course.

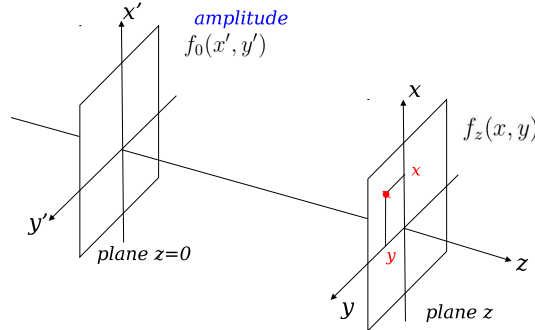

In the observation plane at a point P of coordinates (x, y, z) , we denote as $f_z(x, y)$ the complex amplitude. This notation emphasises the fact that it is a 2D structure in x and y , and that z is here a parameter. The Huygens-Fresnel principle shows that $f_z(x, y)$ expresses as a sum of complex amplitudes produced by all the points of $f_0(x', y')$

$$f_z(x, y) = \frac{1}{i\lambda} \iint_{-\infty}^{\infty} f_0(x', y') \frac{\exp(ik|\vec{r} - \vec{r}'|)}{|\vec{r} - \vec{r}'|} dx' dy' \quad (1.15)$$

where $\vec{r} = (x, y, z)$ and $\vec{r}' = (x', y', 0)$. This integral is indeed a continuous sum of spherical waves centered at every point \vec{r}' on the plane $z = 0$ (Huyghens wavelets).

1.2.2 Paraxial approximation and Fresnel diffraction

When the paraxial approximation is valid, the above integral becomes

$$f_z(x, y) = \frac{e^{ikz}}{i\lambda z} \iint_{-\infty}^{\infty} f_0(x', y') \exp\left(i\pi \frac{(x - x')^2 + (y - y')^2}{\lambda z}\right) dx' dy' \quad (1.16)$$

This paraxial form of the Huyghens-Fresnel principle is known as *Fresnel diffraction* and is valid for $z \gg \left(\frac{d^4}{\lambda}\right)^{\frac{1}{3}}$ with d the size of the diffracting aperture (width of the function $f_0(x', y')$).

The equation 1.16 is a convolution relation, which we can note as:

$$f_z(x, y) = e^{ikz} f_0(x, y) * D_z(x, y) \quad (1.17)$$

where the term e^{ikz} expresses the propagation of a plane wave on the distance z , and

$$D_z(x, y) = \frac{1}{i\lambda z} \exp\left(i\pi \frac{\rho^2}{\lambda z}\right) \quad \text{with} \quad \rho^2 = x^2 + y^2$$

is the complex amplitude of a spherical wave of center O . This convolution relation expresses $f_z(x, y)$ as the sum of spherical waves produced by point-sources in the plane $z = 0$.

The function D_z is the ‘‘amplitude point-spread function’’ of the Fresnel diffraction. It is a normalized function:

$$\iint_{-\infty}^{\infty} D_z(x, y) dx dy = 1$$

1.2.3 A proof of the Huyghens-Fresnel relation in paraxial approximation

A proof of the Eq. 1.17, valid in paraxial approximation, can be given making use of the *angular spectrum* method, involving the decomposition of the complex amplitude $f_0(x, y)$ as a sum of plane waves. The main steps of this proof are

1. Write the function $f_0(x, y)$ as an inverse Fourier transform:

$$f_0(x, y) = \iint_{-\infty}^{\infty} \hat{f}_0(u, v) e^{2i\pi(ux+vy)} dudv$$

2. Make the variable change $\alpha = \lambda u$ and $\beta = \lambda v$. We obtain

$$f_0(x, y) = \frac{1}{\lambda^2} \iint_{-\infty}^{\infty} \hat{f}_0\left(\frac{\alpha}{\lambda}, \frac{\beta}{\lambda}\right) \exp\left[\frac{2i\pi}{\lambda}(\alpha x + \beta y)\right] d\alpha d\beta$$

In the above integral, we assume that the quantity $\hat{f}_0\left(\frac{\alpha}{\lambda}, \frac{\beta}{\lambda}\right)$ vanishes for $|\alpha| > 1$ and $|\beta| > 1$. This is generally true if the width of $f_0(x, y)$ is $\gg \lambda$. In that case, we can replace the limits of the integral by $[-1, 1]$.

The term $\exp\left[\frac{2i\pi}{\lambda}(\alpha x + \beta y)\right]$ is then the complex amplitude of a plane wave (written at $z = 0$), and the above integral expresses the fact that $f_0(x, y)$ is a continuous sum of plane waves. The quantity $\hat{f}_0\left(\frac{\alpha}{\lambda}, \frac{\beta}{\lambda}\right)$ is called the *angular spectrum* of $f_0(x, y)$.

3. Propagate the angular spectrum: in the above integral, each plane wave can be written in the plane z by multiplying its amplitude by a term $e^{ik\gamma z}$ with $\gamma = (1 - \alpha^2 - \beta^2)^{1/2}$. This allows to write the propagated wave $f_z(x, y)$ as:

$$f_z(x, y) = \frac{1}{\lambda^2} \iint_{-\infty}^{\infty} \hat{f}_0\left(\frac{\alpha}{\lambda}, \frac{\beta}{\lambda}\right) \exp\left[\frac{2i\pi}{\lambda}(\alpha x + \beta y + \gamma z)\right] d\alpha d\beta$$

4. Using paraxial approximation, write $\gamma \simeq 1 - \frac{1}{2}(\alpha^2 + \beta^2)$. The integral becomes:

$$f_z(x, y) = e^{ikz} \frac{1}{\lambda^2} \iint_{-\infty}^{\infty} \hat{f}_0\left(\frac{\alpha}{\lambda}, \frac{\beta}{\lambda}\right) \exp\left[\frac{-i\pi z}{\lambda}(\alpha^2 + \beta^2)\right] \exp\left[\frac{2i\pi}{\lambda}(\alpha x + \beta y)\right] d\alpha d\beta$$

5. The variable change $\alpha = \lambda u$, $\beta = \lambda v$ gives

$$f_z(x, y) = e^{ikz} \iint_{-\infty}^{\infty} \hat{f}_0(u, v) \exp[-i\pi\lambda z(u^2 + v^2)] e^{2i\pi(ux+vy)} dudv$$

which is the inverse Fourier transform of the product $\hat{f}_0(u, v) \exp[-i\pi\lambda z(u^2 + v^2)]$. Remarking that $\exp[-i\pi\lambda z(u^2 + v^2)]$ is the Fourier transform of $D_z(x, y)$, we eventually obtain Eq 1.17. More details on the angular spectrum method can be found in the chapter 3.10 of Goodman, ‘‘Introduction to Fourier optics’’.

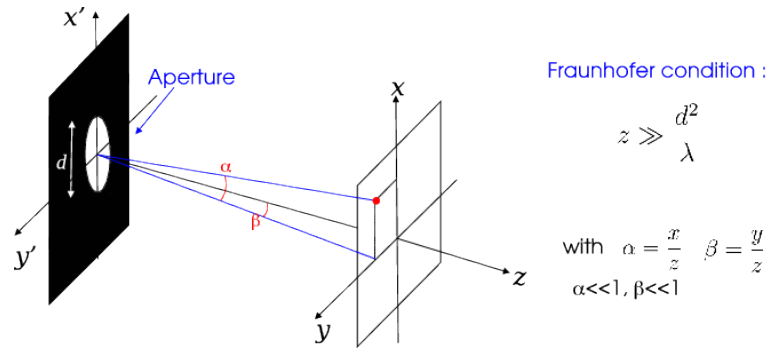

Figure 1.5: Geometry for the Fraunhofer diffraction by an aperture in the plane $z = 0$. x and y are coordinates in the observation plane at large distance z from aperture plane. d is here the aperture diameter.

1.2.4 Far field: Fraunhofer diffraction

Fraunhofer diffraction (or diffraction at infinity) is the limit of the Fresnel diffraction when the distance z tends towards infinity (far-field hypothesis). The equation (1.16) writes as:

$$f_z(x, y) = \frac{e^{ikz}}{i\lambda z} \iint_{-\infty}^{\infty} f_0(x', y') \exp\left(\frac{i\pi z}{\lambda} \left[\frac{\rho^2}{z^2} + \frac{\rho'^2}{z^2} - 2\frac{xx' + yy'}{z^2}\right]\right) dx' dy' \quad (1.18)$$

with $\rho^2 = x^2 + y^2$ and $\rho'^2 = x'^2 + y'^2$. Since $z \rightarrow \infty$, we assume $\rho' \ll z$ (i.e. z much larger than the size of the diffracting aperture) and neglect the second order term in $\frac{\rho'^2}{z^2}$ in the exponential term. The above equation simplifies in

$$f_z(x, y) = \frac{e^{ikz}}{i\lambda z} e^{\frac{i\pi\rho^2}{\lambda z}} \iint_{-\infty}^{\infty} f_0(x', y') \exp\left(-2i\pi \left[x' \frac{x}{\lambda z} + y' \frac{y}{\lambda z}\right]\right) dx' dy' \quad (1.19)$$

We recognise the expression of a Fourier transform

$$f_z(x, y) = \frac{e^{ikz}}{i\lambda z} e^{\frac{i\pi\rho^2}{\lambda z}} \hat{f}_0\left(\frac{x}{\lambda z}, \frac{y}{\lambda z}\right) \quad (1.20)$$

where the symbol $\hat{}$ stands for the Fourier transform. This formula is generally used to express the diffracted amplitude in the Fraunhofer approximation, and makes no assumption on x and y (they can be large, as long as they respect the paraxial approximation criterium).

Further level of approximation: we assume that $\rho \ll z$ in Eq. 1.21. i.e. we restrict the plane (x, y) to a region close to the center. In that case, the term $e^{\frac{i\pi\rho^2}{\lambda z}}$ vanishes and the above formula becomes:

$$f_z(x, y) = \frac{e^{ikz}}{i\lambda z} \hat{f}_0\left(\frac{x}{\lambda z}, \frac{y}{\lambda z}\right) \quad (1.21)$$

This is the formula we will use in the framework of this course to express the Fraunhofer diffraction.

Angular form: we can introduce the quantities $\alpha = \frac{x}{z}$ and $\beta = \frac{y}{z}$, which are angular coordinates of a point in the observation plane as seen from the origin (see Fig. 1.5). We obtain the angular form of the Fraunhofer diffraction formula:

$$f_z(\alpha, \beta) = \frac{e^{ikz}}{i\lambda z} \hat{f}_0\left(\frac{\alpha}{\lambda}, \frac{\beta}{\lambda}\right) \quad (1.22)$$

In the direction α and β , the diffracted amplitude is proportional to the Fourier transform of the screen. The intensity is thus proportional to the power spectrum of $f(x, y)$, i.e. $\left|\hat{f}\left(\frac{\alpha}{\lambda}, \frac{\beta}{\lambda}\right)\right|^2$.

This kind of calculation is often met in the field of signal processing; it is possible to use the phenomenon of Fraunhofer diffraction to realise the 2-dimensional Fourier transform. Experimentally, Fraunhofer conditions can be obtained by diffraction on a distance of several meters or tens of meters. Such an optical setup is somewhat cumbersome and needs a very bright light source (f_z is proportional to $1/z$). But in next chapter we shall see that the use of a converging lens allow to observe Fraunhofer diffraction at finite distance.

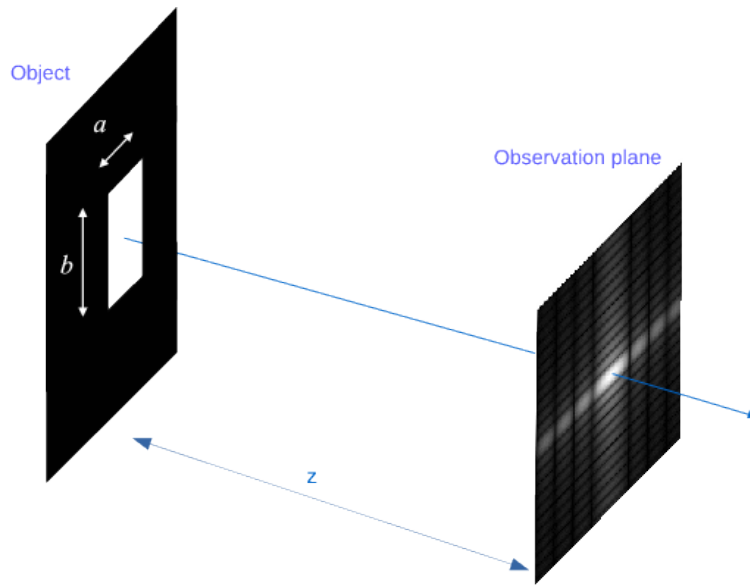

Figure 1.6: Fraunhofer diffraction by a rectangular slit in the plane $z = 0$.

Validity of the approximation

Fraunhofer diffraction is valid if the term $\frac{\rho'^2}{z^2}$ in the exponential term of Eq. 1.18 can be neglected. This exponential term can be developed as:

$$\exp\left(\frac{i\pi z}{\lambda} \left[\frac{\rho^2}{z^2} + \frac{\rho'^2}{z^2} - 2\frac{xx' + yy'}{z^2}\right]\right) = \exp\left(\frac{i\pi\rho^2}{\lambda z}\right) \cdot \exp\left(\frac{i\pi\rho'^2}{\lambda z}\right) \cdot \exp\left(-2i\pi \left[\frac{x'x}{\lambda z} + \frac{y'y}{\lambda z}\right]\right) \quad (1.23)$$

The term in ρ'^2 can be neglected if $\exp\left(\frac{i\pi\rho'^2}{\lambda z}\right) \simeq 1$, thus if $\rho'^2 \ll \lambda z$. If the size of the diffracting aperture is d (so that $\rho' \leq d$ in the integral of Eq. 1.18), we obtain a condition on z to apply Fraunhofer diffraction:

$$z \gg \frac{d^2}{\lambda} \quad (1.24)$$

In the visible domain ($\lambda = 500\text{nm}$), this gives $z > 2\text{m}$ for $d = 1\text{mm}$, and $z > 200\text{m}$ for $d = 1\text{cm}$.

1.2.5 Example of Fraunhofer diffraction patterns

Rectangular slit

The object is a rectangular slit of width a in the x direction and b in the y direction (see Fig. 1.6). Its transmission can be written as

$$t(x, y) = \Pi\left(\frac{x}{a}\right) \Pi\left(\frac{y}{b}\right) \quad (1.25)$$

We suppose that this slit is lit by a plane wave under normal incidence whose amplitude is A in the plane of the slit. Applying Eq. 1.21, the diffracted amplitude at distance z under Fraunhofer approximation is

$$f_z(x, y) = A e^{ikz} \frac{ab}{i\lambda z} \text{sinc}\left(\frac{\pi ax}{\lambda z}\right) \text{sinc}\left(\frac{\pi by}{\lambda z}\right) \quad (1.26)$$

The graph of the corresponding intensity is displayed in Fig. 1.7. It exhibits, in both directions, a central lobe surrounded by secondary maxima. The brightest secondary maximum has an intensity of 4.5% of the maximum. The half-size of the central lobe in the x (resp y) direction is $\lambda z/a$ (resp. $\lambda z/b$), inversely proportional to the slit width. The position of the secondary minima (in the x direction) is periodically distributed at $p\lambda z/a$ ($p \neq 0$).

Circular diaphragm

The object is a circular aperture of diameter a . Its transmission is

$$t(x, y) = \Pi\left(\frac{\rho}{a}\right) \quad \text{with} \quad \rho = \sqrt{x^2 + y^2} \quad (1.27)$$

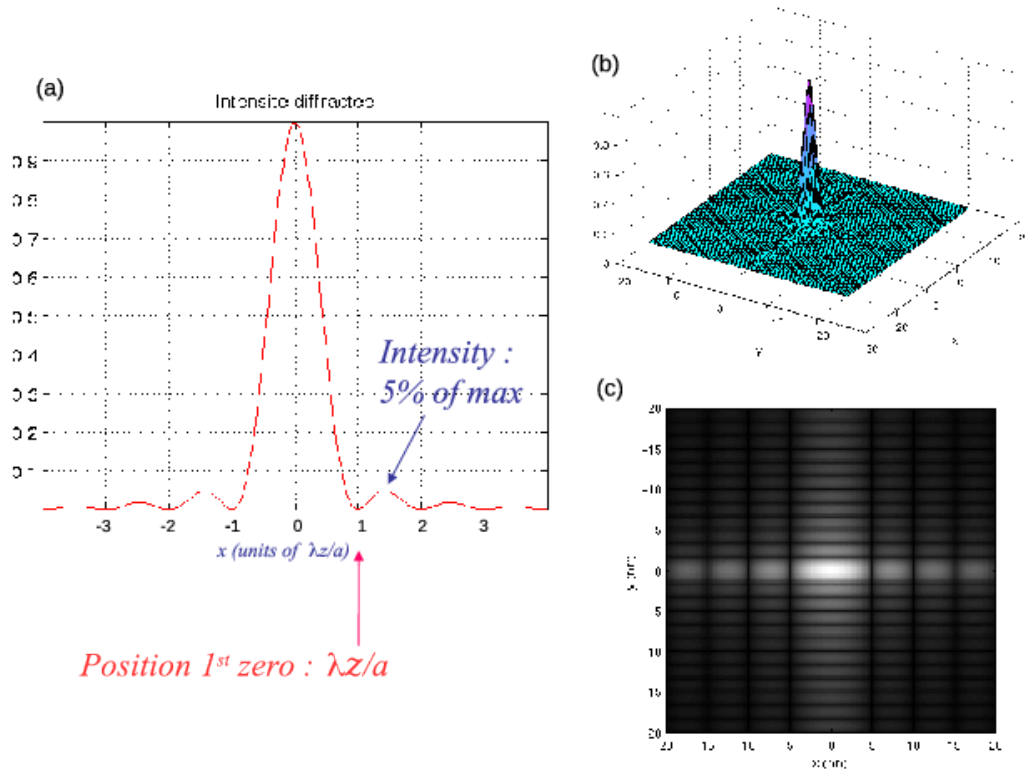

Figure 1.7: Intensity diffracted by a rectangular slit in Fraunhofer approximation. (a) Plot of the normalised intensity as a function of x . (b) Perspective plot of the 2D intensity in the (x, y) plane. (c) Gray level plot showing the aspect of the image.

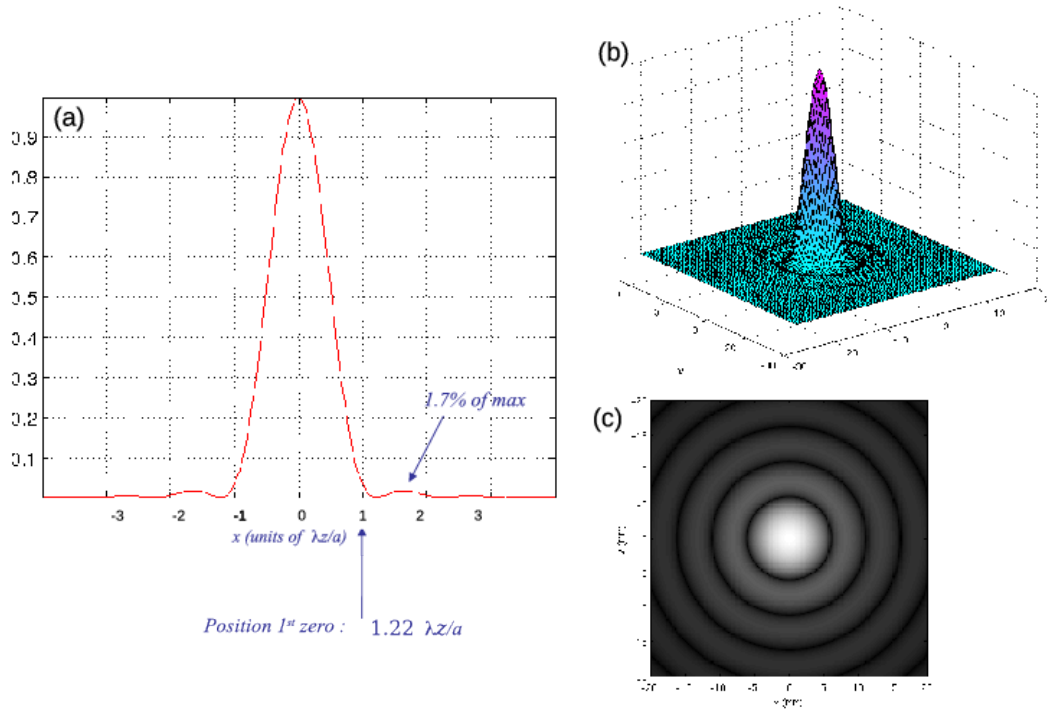

Figure 1.8: Airy disc: intensity diffracted by a circular aperture. (a) Plot of the normalised intensity as a function of x . (b) Perspective plot of the 2D intensity in the (x, y) plane. (c) Gray level plot showing the aspect of the image.

As for the previous example, the incident wave is plane with normal incidence and amplitude A in the aperture plane. Note that the wave in the plane $z = 0$ is invariant by rotation around the z -axis: its diffraction pattern has the same symmetry. The diffracted amplitude at distance z is

$$f_z(x, y) = A e^{ikz} \frac{S}{i\lambda z} 2 \operatorname{jinc} \left(\frac{\pi a \rho}{\lambda z} \right) \quad \text{with} \quad S = \frac{\pi a^2}{4} \quad (\text{aperture surface}) \quad (1.28)$$

which looks very similar to the amplitude diffracted by a slit of same width a , excepted that the sinc function is replaced by a jinc (preceded by a multiplicative factor 2 because $\operatorname{jinc}(0) = \frac{1}{2}$). The intensity is the well-known *Airy* function:

$$I(x, y) = \frac{|A|^2 S^2}{(\lambda z)^2} 4 \operatorname{jinc}^2 \left(\frac{\pi a \rho}{\lambda z} \right) \quad (1.29)$$

its graph is displayed in Fig. 1.8. It has the appearance of a bright disc surrounded by faint rings (Airy disc). The radius of the central lobe is $1.22 \lambda z/a$. The first secondary ring has an intensity of 1.7% of the maximum. Note that radii of dark rings is not periodic (as it was the case for the slit).

It is interesting to compare the diffraction patterns (intensity) produced by a disc of diameter a and a square of same side a (Fig. 1.9). Some differences may be noticed:

- the size of the central lobe is larger in the case of the disc (by 22%),
- the central lobe contains more energy in the case of the disc (84% of the integrated intensity for the disc, 81% for the square),
- secondary maxima are fainter for the disc (1st maximum at 1.7% of the central intensity for the disc, 4.5% for the square),
- secondary minima are periodically distributed for the square, not for the disc.

1.2.6 Diffraction gratings

Introduction

These are regular masks composed of the periodic repetition of a pattern in one or two directions. In this course, we will only consider one-dimensional gratings, periodic in a single direction (x) and infinite in the perpendicular direction (y).

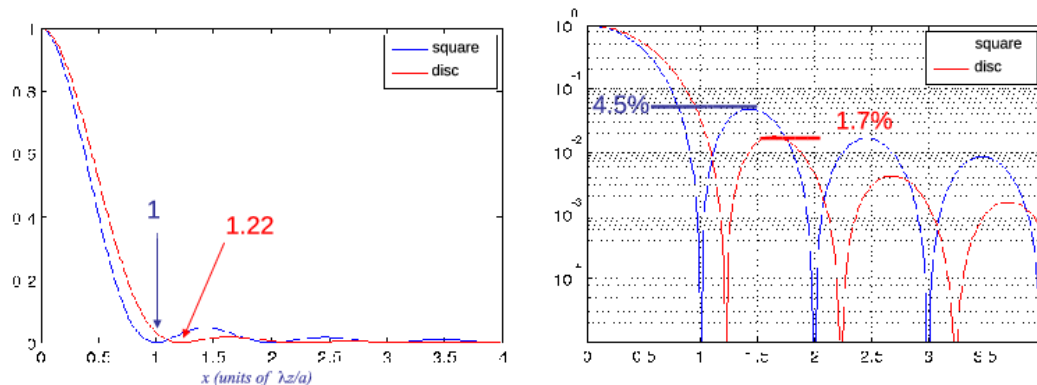

Figure 1.9: Comparison between Fraunhofer diffraction patterns of a disc of diameter a and a square aperture of same side a . Left: graph of the intensities (normalised so that the maximum is 1). Right: same in semi-logarithmic scale.

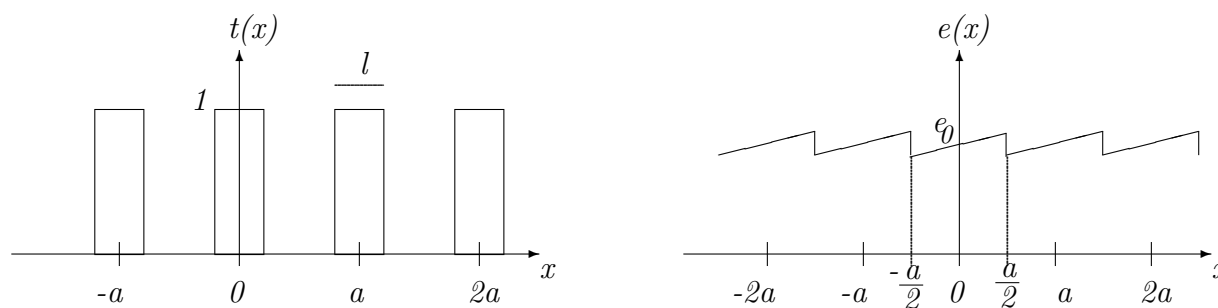

Figure 1.10: Two examples of diffraction gratings. On the left, an amplitude grating consisting of transparent stripes of width l equidistant by a . The transmission coefficient of this grating is written as $t(x) = \sum_n \Pi\left(\frac{x-na}{l}\right)$. The grating on the right is a phase grating formed by a glass plate with periodic thickness variations (small sawtooth structures with an angle α). The transmission coefficient of the central pattern is $\phi(x) = \Pi\left(\frac{x}{a}\right) \exp\left(\frac{2i\pi}{\lambda}(n-1)(e_0 + \alpha x)\right)$.

The transmission coefficient of such an object is generally written as

$$t(x) = \sum_{n=1}^N \phi(x - na) \tag{1.30}$$

where $\phi(x)$ is the transmission coefficient of the central pattern, N is the number of patterns, and a is the period. There are amplitude gratings (e.g., black stripes on a transparent background like Ronchi rulings), phase gratings (periodic variation of the thickness of a plate), or a combination of both. Examples are given in Figure 1.10.

As we will see later, gratings split an incident plane wave into multiple secondary waves propagating in different directions. This principle was discovered by Rittenhouse in 1785. The first gratings made by Young in 1801 consisted of tightly wound thin wires stretched between two screws, probably ineffective in the visible range where the spacing between the wires is large compared to the wavelength. Fraunhofer (1819) then created gratings using thin gold ribbons deposited on a glass plate. However, it was Rowland who introduced the technique of engraving a glass plate with a diamond tip (1882), allowing the first mass production of diffraction gratings.

Reflection gratings Nowadays, reflection gratings are the most commonly used. These are glass surfaces engraved (with a few hundred lines per millimeter for gratings operating in the visible spectrum) and then aluminized or silvered. These gratings behave like mirrors and have the advantage of avoiding light transmission through the glass, which could alter the wave due to potential material defects. They are also easier to manufacture by replicating existing gratings.

A reflection grating is characterized by its periodic reflection coefficient $r(x, y)$. As with transmission gratings, two families can be distinguished:

- $r(x, y)$ real: example of opaque lines on a reflective surface.

- $r(x, y)$ complex: example of a sawtooth-profile grating as shown in Figure 1.10 – the thickness of air traversed between the incident and reflected wave is a periodic function.

Diffraction of a plane wave by a grating

We consider a transmission grating that is periodic in the x direction, invariant under translation in the y direction, and infinite in both the x and y directions. Its transmission coefficient is written as the periodic repetition of its pattern:

$$t(x) = \sum_{n=-\infty}^{\infty} \phi(x - na) \quad (1.31)$$

This grating, placed in the plane $z = 0$, is illuminated by a monochromatic plane wave with an incidence of α_0 . The complex amplitude in the plane $z = 0^-$ is:

$$f_{0-}(x, y) = \psi_0 e^{ik\alpha_0 x} \quad (1.32)$$

with k the wave number. At the output of the grating, the wave is written as:

$$f_0(x, y) = \psi_0 e^{ik\alpha_0 x} \sum_{n=-\infty}^{\infty} \phi(x - na) \quad (1.33)$$

Using Poisson's summation formula (Fourier series expansion of the function $t(x, y)$ ¹ will reveal that $f_0(x, y)$ is a sum of plane waves propagating in different directions. Thus:

$$f_0(x, y) = \frac{\psi_0}{a} \sum_{n=-\infty}^{\infty} \hat{\phi}\left(\frac{n}{a}\right) \exp\left[ik\left(\alpha_0 + n\frac{\lambda}{a}\right)x\right] \quad (1.34)$$

Here, we recognize the expression in the plane $z = 0$ of a discrete sum of plane waves propagating in directions ($\alpha_n = \alpha_0 + n\frac{\lambda}{a}, \beta_n = 0$), with amplitudes $\psi_{0n} = \frac{\psi_0}{a} \hat{\phi}\left(\frac{n}{a}\right)$. A plane incident wave is thus transformed into **multiple secondary plane waves**. It is remarkable to note that the propagation directions of these secondary waves depend solely on the grating period, whereas their amplitudes depend only on the shape of the pattern.

Diffraction orders

The index “ n ” in the sum characterizes the propagation direction α_n . This is referred to as “order n ”. The deviation of the wave at order n is expressed by the so-called “grating equation”:

$$\boxed{\sin \theta_n - \sin \theta_0 = n \frac{\lambda}{a}} \quad (1.35)$$

where $\alpha_n = \sin \theta_n$. We observe that part of the incident light is not deviated (order $n = 0$), while the remaining light energy is distributed among the other orders.

Typical values: for a grating with 500 lines/mm (period $a = 2 \mu\text{m}$), lit in normal incidence ($\theta_0 = 0$) at a wavelength $\lambda = 600 \text{ nm}$, the deviation angles θ_n for orders 1 and 2 are: $\theta_1 = 17^\circ$, $\theta_2 = 37^\circ$. We can remark that:

1. Different wavelengths are deviated in different directions, except for the order 0. In white light, colors are observed. This is why gratings are used in spectrographs.
2. There is a maximum order since $\sin \theta_n$ cannot exceed 1. Thus, we always have:

$$n < \frac{\lambda}{a}$$

3. Only order 0 is observed if the grating period is smaller than the wavelength.

¹Poisson's formula: $\sum_n \phi(x - na) = \frac{1}{a} \sum_n \hat{\phi}\left(\frac{n}{a}\right) \exp\left(\frac{2i\pi nx}{a}\right)$

Physical significance of the orders Consider the following diagram, where the grating consists of small equidistant slits illuminated at normal incidence.

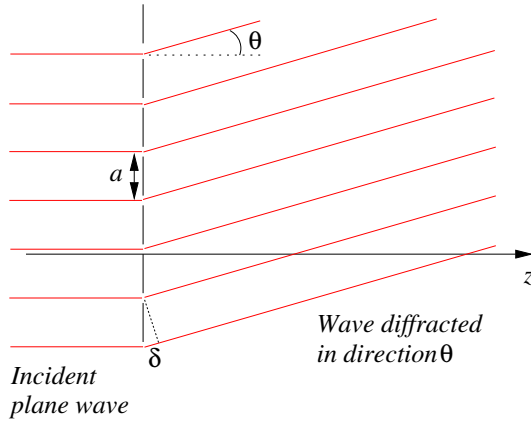

The path difference between two waves originating from two neighboring slits is given by: $\delta = a \sin \theta$. Light is observed only in directions where the interference is constructive, meaning in directions θ_n such that:

$$\delta = a \sin \theta_n = n\lambda$$

This leads to the “grating equation” that determines the deviation of order n . The reason why the maximum observable order is $\frac{\lambda}{a}$ can also be understood from this diagram: it is simply because the maximum path difference between two successive waves, occurring when the emerging wave propagates vertically ($\theta = \pi/2$), is equal to the slit spacing a .

Fraunhofer diffraction pattern

Using the same notations as in the previous section, the wave at the output of the grating is given by Eq. 1.34:

$$f_0(x, y) = \frac{\psi_0}{a} \sum_{-\infty}^{\infty} \hat{\phi}\left(\frac{n}{a}\right) \exp\left[ik\left(\alpha_0 + n\frac{\lambda}{a}\right)x\right] \tag{1.36}$$

The diffracted amplitude in the direction (α, β) at large distance z is expressed as (Eq. 1.22):

$$f_z(\alpha, \beta) = \frac{e^{ikz}}{i\lambda z} \hat{f}_0\left(\frac{\alpha}{\lambda}, \frac{\beta}{\lambda}\right) \tag{1.37}$$

which leads to:

$$f_z(\alpha, \beta) = \frac{\lambda\psi_0}{a} \frac{e^{ikz}}{iz} \delta(\beta) \sum_{-\infty}^{\infty} \hat{\phi}\left(\frac{n}{a}\right) \delta\left(\alpha - \left(\alpha_0 + n\frac{\lambda}{a}\right)\right) \tag{1.38}$$

The intensity is given by:

$$I(\alpha, \beta) = \text{Constant} \sum_{-\infty}^{\infty} \left|\hat{\phi}\left(\frac{n}{a}\right)\right|^2 \delta\left(\alpha - \left(\alpha_0 + n\frac{\lambda}{a}\right)\right) \delta(\beta) \tag{1.39}$$

The graphical representation of this function (see the following figure) in the $(\alpha = \sin \theta_x, \beta = \sin \theta_y)$ plane reveals a series of bright spots with intensities weighted by $\left|\hat{\phi}\left(\frac{n}{a}\right)\right|^2$, corresponding to the diffraction orders. The figure is compressed along the line $\beta = 0$, and order 0 is observed in the direction $\alpha = \alpha_0$.

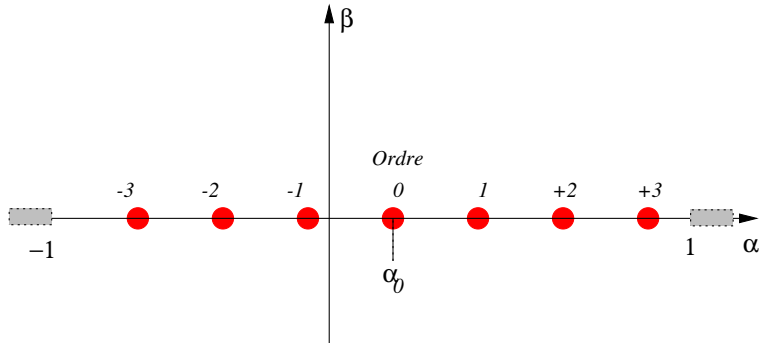

Finite-size gratings — Resolving power

Real gratings are, of course, not infinite in both directions; they are usually engraved on glass plates or plastic films (photographic gratings) and have a typical size of a few centimeters:

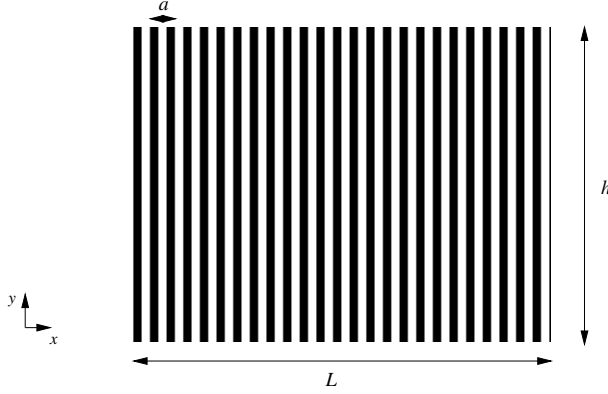

The total number of lines, $N = L/a$, is typically between a few thousand and tens of thousands. The transmission coefficient of a finite-size grating is obtained by multiplying that of an infinite grating by gate functions that enforce spatial limitation:

$$t(x, y) = \Pi\left(\frac{x}{L}\right) \Pi\left(\frac{y}{h}\right) \sum_{n=-\infty}^{\infty} \phi(x - na) \quad (1.40)$$

The new diffracted amplitude at infinity is then given by the convolution:

$$f_z(\alpha, \beta) = \frac{\lambda\psi_0}{a} \frac{e^{ikz}}{iz} \sum_{-\infty}^{\infty} \hat{\phi}\left(\frac{n}{a}\right) \left[\delta\left(\alpha - \left(\alpha_0 + n\frac{\lambda}{a}\right)\right) \cdot \delta(\beta) \right] * \frac{hL}{\lambda^2} \left[\text{sinc}\left(\frac{\pi\alpha L}{\lambda}\right) \text{sinc}\left(\frac{\pi\beta h}{\lambda}\right) \right] \quad (1.41)$$

Rearranging terms and using the properties $f(x) * \delta(x - a) = f(x - a)$ and $f(x)\delta(x - a) = f(a)\delta(x - a)$, we obtain:

$$f_z(\alpha, \beta) = \frac{hL\psi_0 e^{ikz}}{iaz\lambda} \sum_{-\infty}^{\infty} \hat{\phi}\left(\frac{n}{a}\right) \text{sinc}\left(\frac{\pi L}{\lambda} \left(\alpha - \alpha_0 - n\frac{\lambda}{a}\right)\right) \text{sinc}\left(\frac{\pi\beta h}{\lambda}\right) \quad (1.42)$$

Comparing this with the infinite grating case, we see that all Dirac peaks are replaced by sinc functions, corresponding to the diffraction pattern of the spatial limitation rectangle $\Pi\left(\frac{x}{L}\right) \Pi\left(\frac{y}{h}\right)$. The overall shape is roughly:

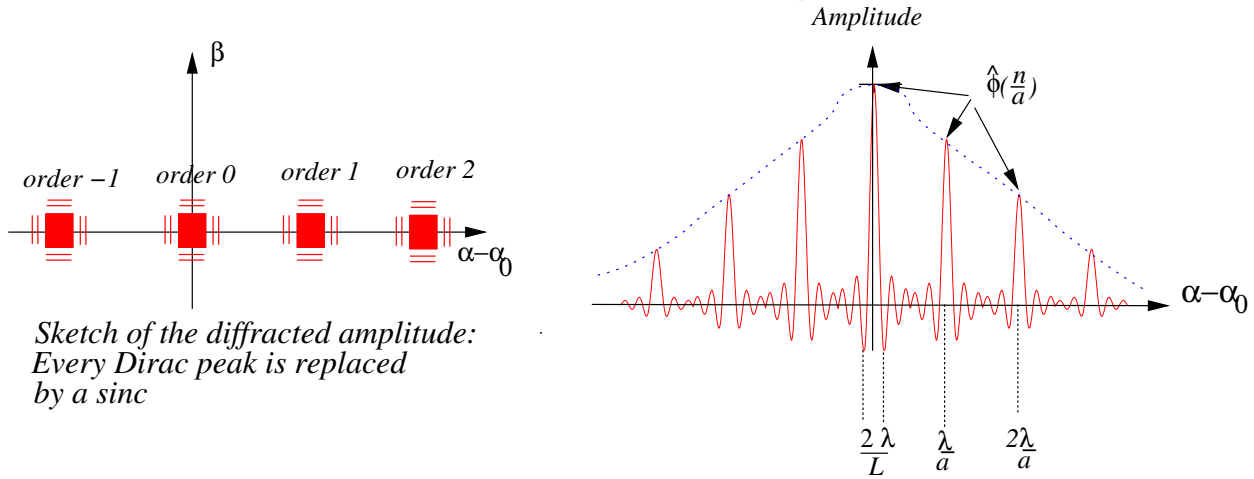

Expression of intensity It is the squared modulus of the complex amplitude from the previous expression, so we formally have:

$$I(\alpha, \beta) = \frac{h^2 L^2 |\psi_0|^2}{a^2 z^2 \lambda^2} \left| \sum_{-\infty}^{\infty} \hat{\phi}\left(\frac{n}{a}\right) \text{sinc}\left(\frac{\pi L}{\lambda} \left(\alpha - \alpha_0 - n\frac{\lambda}{a}\right)\right) \text{sinc}\left(\frac{\pi\beta h}{\lambda}\right) \right|^2 \quad (1.43)$$

Let $I_0 = \frac{h^2 L^2 |\psi_0|^2}{a^2 z^2 \lambda^2}$, then the squared expansion reveals squared terms and cross-product terms:

$$I = I_0 \left(\sum_n \text{squared terms} + 2 \sum_n \sum_{n \neq m} \text{cross-product terms} \right)$$

We consider the common case where the size of the grating is much larger than its period, i.e., $L \gg a$. Under this assumption, the width of the orders $\frac{2\lambda}{L}$ is much smaller than their separation $\frac{\lambda}{a}$ (no overlap between successive orders). In this case, the cross terms in the above sum are nearly zero (as they involve amplitudes from different orders $n \neq m$), and we can write:

$$I(\alpha, \beta) \simeq I_0 \sum_{-\infty}^{\infty} \left| \hat{\phi} \left(\frac{n}{a} \right) \right|^2 \text{sinc}^2 \left(\frac{\pi L}{\lambda} \left(\alpha - \alpha_0 - n \frac{\lambda}{a} \right) \right) \text{sinc}^2 \left(\frac{\pi \beta h}{\lambda} \right) \quad (1.44)$$

Resolving Power Let us imagine that the grating is illuminated by two monochromatic plane waves of nearby wavelengths λ_1 and λ_2 , both arriving at the same incidence.

- For the wavelength λ_1 , the grating diffracts a sum of plane waves in directions

$$\alpha_{n1} = \alpha_0 + n\lambda_1/a$$

- For the wavelength λ_2 , the waves are diffracted in directions

$$\alpha_{n2} = \alpha_0 + n\lambda_2/a$$

Two vibrations of different frequencies are incoherent with each other, and thus the two diffraction intensities add up, producing a graph showing a splitting of each order (except for the zeroth order):

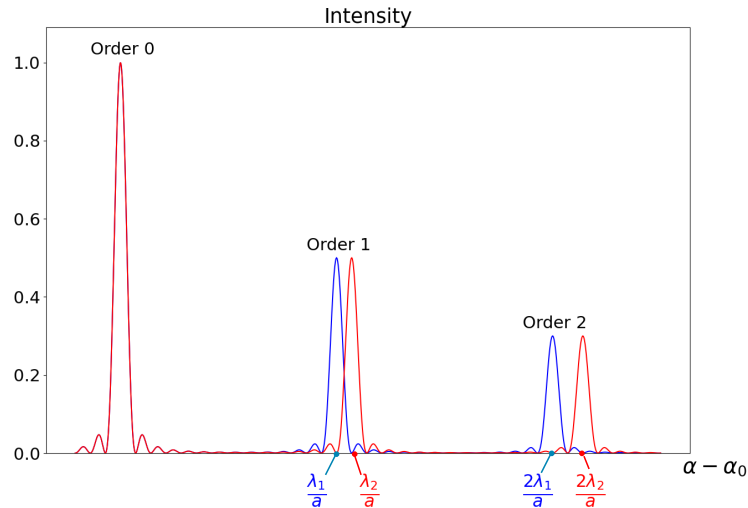

The separation $\Delta\alpha$ between the two peaks corresponding to order n is given by:

$$\Delta\alpha = n \frac{\delta\lambda}{a} \quad (1.45)$$

if $\delta\lambda = \lambda_2 - \lambda_1$. If this distance is smaller than the half-width λ/a of the order, only one peak will be observed (the two spots are merged into a single one).

In this case, the grating is not capable of resolving the two wavelengths at order n . The critical case, where the two peaks are just separated, is obtained when the separation between peaks equals the half-width. In this situation, the maximum of the peak corresponding to λ_1 is coincident with the first zero of the peak corresponding to λ_2 :

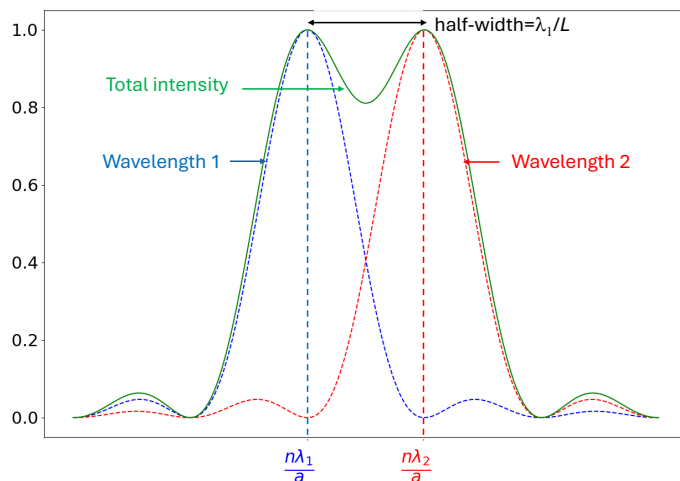

The minimum wavelength difference that the grating can resolve at order n is then:

$$\delta\lambda = \frac{a\lambda}{nL} \quad (1.46)$$

where $\lambda = \lambda_1 \simeq \lambda_2$ (in such a case, the difference between λ_1 and λ_2 is small). The *resolving power* of the grating is defined as:

$$R = \frac{\lambda}{\delta\lambda} = \frac{nL}{a} \quad (1.47)$$

which is the product of the order and the number of lines in the grating. Typical values range from a few thousand to tens of thousands.

Application example We want to resolve the Sodium doublet, $\lambda_1 = 5890 \text{ \AA}$, $\lambda_2 = 5896 \text{ \AA}$; what resolving power is required? If we use a grating with 100 lines/mm at order 1, what should its size be?

→ The separation $\delta\lambda$ is 6 \AA , while λ_1 and λ_2 are close to 6000 \AA , so the required resolution is:

$$R = \frac{\lambda}{\delta\lambda} \simeq 1000$$

→ For a grating with 100 lines/mm ($a = 0.01 \text{ mm}$) at order 1, the required size is:

$$L = aR = 10 \text{ mm}$$

Another Example A spectroscope is used to measure the radial velocity of binary stars. With a grating resolution of 60 000 at order 1, what is the minimum measurable velocity?

→ The wavelength shift in the spectra of the two stars is a consequence of the Doppler effect. If v_r is the radial velocity difference of the two stars, then the Doppler shift is:

$$\frac{\delta\lambda}{\lambda} = \frac{v_r}{c}$$

→ With a grating resolution of R , the minimum detectable radial velocity is:

$$v_r = c \frac{\delta\lambda}{\lambda} = \frac{c}{R} = 5 \text{ km/s}$$

Chapter 2

Fourier properties of converging lenses

Also read:

- Goodman, J.W., “Introduction to Fourier Optics”, chap 5

2.1 Phase screens

2.1.1 Transmission coefficient of a thin phase screen

It can be considered that transparent objects with variable thickness $e(x, y)$ (e.g. prisms, lenses, glass plates) and/or variable refraction index $n(x, y)$ (for example a layer of gas with inhomogeneous temperature) act as screens introducing a phase shift. The associated transmission coefficient $t(x, y)$ is a complex phase term which takes the form :

$$t(x, y) = e^{ik\Delta} \exp [ik(n - 1) e(x, y)] \tag{2.1}$$

with k the wave number of the incoming light and Δ the maximal thickness of the plate. Paraxial approximation is assumed here so that we consider that the trajectory in the material is $e(x, y)$ whatever the incidence of the wave, neglecting effects of inclinations. This relation is true only if the phase screens are thin.

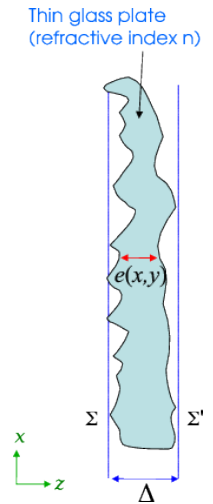

Proof: The plate is enclosed between two parallel planes (see graph above) Σ (corresponding to $z = 0$) and Σ' (at $z = \Delta$). We consider a plane incident wave with normal incidence. Its complex amplitude at the entrance plane Σ is a constant

$$f_0(x, y) = A$$

In the exit plane $z = \Delta$, the light ray crossing the point (x, y) has travelled a distance $e(x, y)$ in the material¹, and $\Delta - e(x, y)$ in the vacuum, so that the complex amplitude is

$$f_{\Delta}(x, y) = A e^{ikn e(x, y)} e^{ik(\Delta - e(x, y))}$$

which is the product of two terms:

$$f_{\Delta}(x, y) = f_0(x, y) e^{ik\Delta} \exp[ik(n - 1)e(x, y)] \tag{2.2}$$

the influence of the plate is a multiplicative term $t(x, y) = e^{ik\Delta} \exp[ik(n - 1)e(x, y)]$.

We generally neglect the constant term $e^{ik\Delta}$ and write the transmission coefficient of the plate as

$$\boxed{t(x, y) = \exp [ik(n - 1)e(x, y)]} \tag{2.3}$$

¹assuming that the ray goes almost parallel to the z axis so that it hits the planes Σ and Σ' at the same transverse coordinates (x, y) : this approximation is possible only for thin plates.

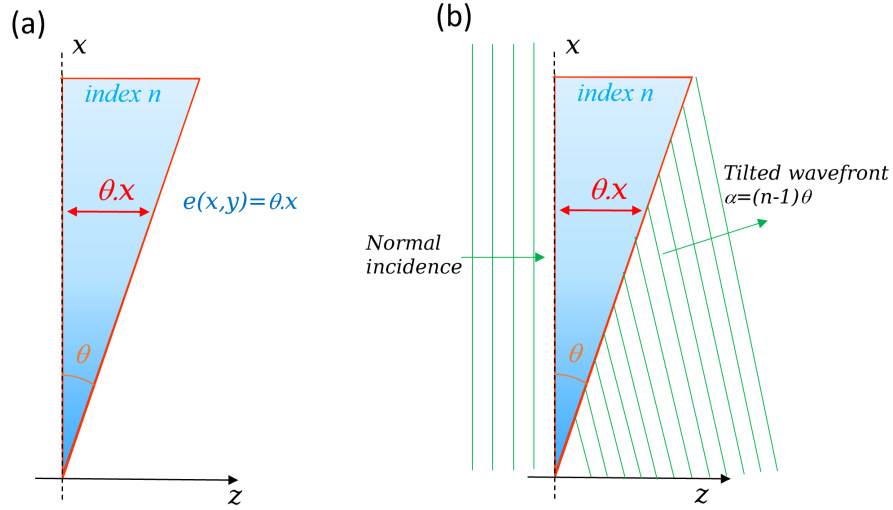

Figure 2.1: (a): glass prism of refractive index n . The thickness function is $e(x, y) = \theta x$ with $\theta \ll 1$. (b): illustration of the deviation of a plane wave with normal incidence by the prism. The new incidence is $\alpha = (n - 1)\theta$.

2.1.2 Example: prism

We consider the glass prism of Fig. 2.1a with a thickness $e(x, y) = \theta x$ and $\theta \ll 1$. The transmission of this prism is

$$t(x, y) = \exp[ik(n - 1)\theta x] \quad (2.4)$$

Note that we have neglected the edges of the prism, considering that it has an infinite extension in the plane (x, y) . The above transmission coefficient is indeed to be multiplied by an adequate gate function. If the prism is lit by a plane wave under normal incidence and complex amplitude ψ_0 at the entrance plane of the prism (taken as $z = 0$), then the exit amplitude (in the plane $z = \Delta$) is

$$f(x, y) = \psi_0 e^{ik(n-1)\theta x} \quad (2.5)$$

which is, in paraxial approximation, the amplitude of a plane wave (linear phase in x , see Section 1.1.2) of wave vector

$$\vec{k} = \frac{2\pi}{\lambda} \begin{pmatrix} \alpha = (n - 1)\theta \\ \beta = 0 \\ \gamma \end{pmatrix} \quad \text{the coefficient } \gamma \text{ does not appear explicitly here since the amplitude is written in the plane } z = 0.$$

It can be calculated using the relation $\alpha^2 + \beta^2 + \gamma^2 = 1$. Note that the tilt angle of this wave is $(n - 1)\theta$, a result well-known in geometric optics (see Fig. 2.1b).

2.1.3 Converging lens

We consider a plano-convex lens of refractive index n and radius of curvature R (Fig. 2.2a). The curved surface is a portion of sphere which can be approximated by a paraboloid if the lens is thin (e.g. $R \gg \Delta$). In this case the thickness function expresses as

$$e(x, y) \simeq \Delta - \frac{\rho^2}{2R} \quad (2.6)$$

with $\rho^2 = x^2 + y^2$. The transmission coefficient (neglecting the constant term in Δ) is

$$t(x, y) = \exp \left[-ik(n - 1) \frac{\rho^2}{2R} \right] \quad (2.7)$$

let's introduce the *focal length* F of the lens

$$F = \frac{R}{n - 1} \quad (2.8)$$

the transmission of the lens is a quadratic phase term which will now be denoted using the notation $L_F(x, y)$:

$$L_F(x, y) = \exp \left[-\frac{i\pi\rho^2}{\lambda F} \right] \quad (2.9)$$

²the exit amplitude should be written in the exit plane $z = \Delta$ with Δ the maximum thickness of the prism. However we neglected the term $e^{ik\Delta}$ in the transmission coefficient: that is similar to write the exit amplitude back in the plane $z = 0$.

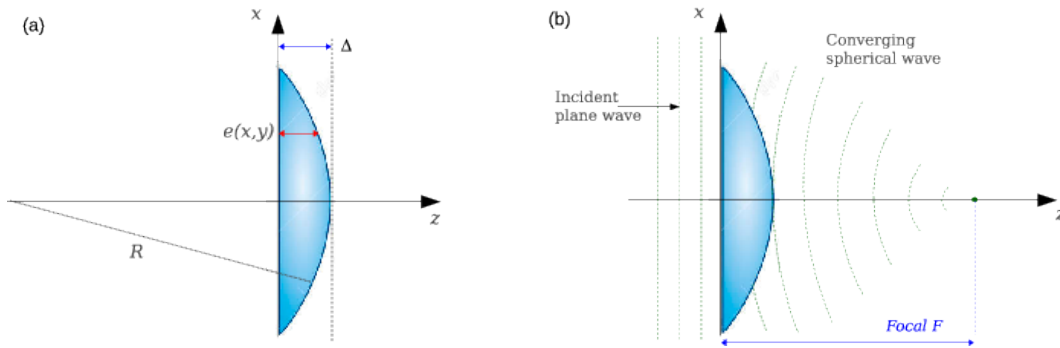

Figure 2.2: (a): Plano-convex lens of refraction index n . The exit surface is a portion of sphere of radius of curvature R and maximum thickness Δ . (b): Transformation of an incident plane wave into a converging spherical wave at the exit of the lens. The center of this converging wave is at $z = F$ (focal length of the lens).

As for the example of the prism above, we have neglected the edges of the lens, considering an infinite extension in the (x, y) plane. The complete transmission coefficient is obtained by multiplying $L_F(x, y)$ by a 2D circular function. If the lens is lit by a plane wave under normal incidence and complex amplitude ψ_0 at the entrance plane of the lens (plane $z = 0$), then the exit amplitude (in the plane $z = 0^+$) is

$$f_{0+}(x, y) = \psi_0 e^{-\frac{i\pi\rho^2}{\lambda F}} \quad (2.10)$$

the quadratic phase term in x and y is the signature of a spherical wave under paraxial approximation (see Section 1.1.3) of center $(0, 0, F)$, and the minus sign in the exponential shows that this is a converging wave. This is illustrated by the figure 2.2b. The plane $z = F$ is called *back focal plane* (or just “focal plane”) of the lens.

Case of a diverging lens: a similar calculation shows that the transmission of a diverging lens of focal F is obtained by changing F into $-F$ in the equation 2.9, so that it can be denoted as “ $L_{-F}(x, y)$ ”:

$$L_{-F}(x, y) = \exp \left[+\frac{i\pi\rho^2}{\lambda F} \right] \quad (2.11)$$

It is thus possible to define a *generalized focal length*, positive for a converging lens and negative for a diverging lens, and use Eq. 2.9 for both cases.

2.2 Converging lenses and Fourier transform

In this section we consider an ensemble formed by an object of transmission $t(x, y)$ and a converging lens. This ensemble is lit under normal incidence by a plane wave. The aim is to write down the complex amplitude at the focal plane of the lens. Two cases will be considered:

- the object is attached to the lens (they are in the same plane),
- the object is in the *front focal plane* of the lens (distance $z = -F$ from the lens)

The figure 2.3 shows the optical configuration for the two cases.

2.2.1 Object in the same plane as the lens

We use the following conventions:

- the plane of the object/lens is at $z = 0$
- coordinates in the plane $z = 0$ are denoted (x', y') , and (x, y) in the focal plane $z = F$
- the complex amplitude of the incident wave (for $z < 0$) is $\psi_0 e^{ikz}$ (normal incidence, $\vec{k} \parallel \hat{z}$)

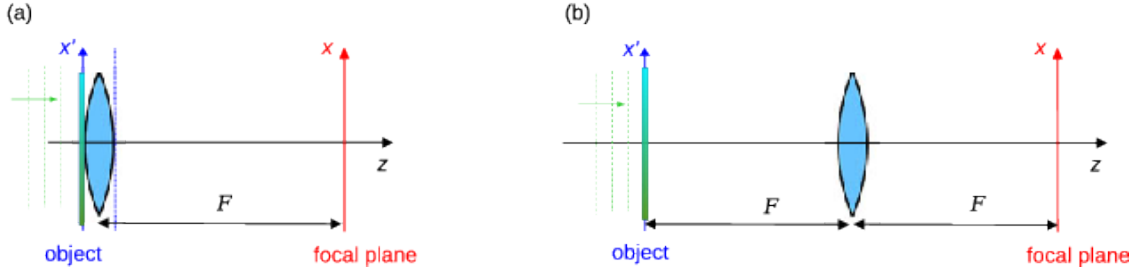

Figure 2.3: Optical scheme for the observation of the 2D Fourier transform of the transmission of an object using a converging lens. (a): Object in the same plane as the lens. (b): Object at the front focal plane of the lens.

The optical configuration is shown in Fig. 2.3a. To calculate the complex amplitude in the plane $z = F$, we have to write the amplitude just after the lens ($z = 0^+$), then do a Fresnel diffraction to the plane $z = F$.

The complex amplitude just before the lens ($z = 0^-$) is the product

$$f_0(x', y') = \psi_0 t(x', y') \quad (2.12)$$

After the lens, it becomes

$$f_{0+}(x', y') = f_0(x', y') L_F(x', y') \quad (2.13)$$

The Fresnel diffraction to the plane $z = F$ is given by Eq 1.17:

$$f_F(x, y) = e^{ikF} f_{0+}(x, y) * D_F(x, y) \quad (2.14)$$

with $D_F(x, y) = \frac{1}{i\lambda F} e^{\frac{i\pi\rho^2}{\lambda F}}$. By expanding the convolution product, it can be put into the following form (known as *Fresnel transform*):

$$f_F(x, y) = \frac{e^{ikF}}{i\lambda F} e^{\frac{i\pi\rho^2}{\lambda F}} \mathcal{F} \left[f_{0+}(x', y') e^{\frac{i\pi\rho'^2}{\lambda F}} \right]_{u=\frac{x}{\lambda F}, v=\frac{y}{\lambda F}} \quad (2.15)$$

with $\rho'^2 = x'^2 + y'^2$ and \mathcal{F} the Fourier transform. The curvature phase term $e^{\frac{i\pi\rho'^2}{\lambda F}}$ in the brackets simplifies with the coefficient $L_F(x', y')$ so that the complex amplitude in the focal plane is

$$f_F(x, y) = \frac{e^{ikF}}{i\lambda F} e^{\frac{i\pi\rho^2}{\lambda F}} \hat{f}_0 \left(\frac{x}{\lambda F}, \frac{y}{\lambda F} \right) \quad (2.16)$$

Hence, in the focal plane the amplitude is proportional to the Fourier transform of the amplitude in the plane $z = 0$. The intensity is

$$I(x, y) = \frac{1}{\lambda^2 F^2} \left| \hat{f}_0 \left(\frac{x}{\lambda F}, \frac{y}{\lambda F} \right) \right|^2 \quad (2.17)$$

As for a Fraunhofer diffraction (see Section 1.2.4), it is possible to observe the 2D power spectrum $|\hat{f}_0(u, v)|^2$ of the complex amplitude at the entrance of the lens. Note that this observation is valid only in the focal plane of the lens (otherwise a Fresnel diffraction between the focal plane and the observation plane applies).

An astrophysical application of this Fourier property was made by Labeyrie in 1970 in his historical paper about speckle interferometry (Labeyrie A., 1970, "Attainment of Diffraction Limited Resolution in Large Telescopes by Fourier Analysing Speckle Patterns in Star Images", A&A **6**, 85). Labeyrie needed to accumulate power spectra of short exposure photographs of stars, and he did it using an optical bench (a laser beam passing through the photographic film, a lens and a photographic plate recording the power spectrum).

In the absence of object ($t(x', y') = 1$) the diffracted amplitude is proportional to a Dirac function $\delta(x, y)$, which explicits the focusing effect of a converging lens on the axis.

The multiplicative phase curvature $e^{\frac{i\pi\rho^2}{\lambda F}}$ in Eq. 2.16 may be cancelled by adding a second converging lens of focal F in the focal plane. But we shall see hereafter that this phase term vanishes if the object is placed at the distance F if front of the lens.

2.2.2 Object at the front focal plane

The optical scheme is shown in Fig. 2.3b. The object is at a distance F in front of the lens (front focal plane). To calculate the amplitude at the back focal plane $z = 2F$ we use a plane by plane approach, and successively calculate complex amplitudes in the 3 planes of interest (object, lens, focal).

Object plane $z = 0$: the complex amplitude just after the object is denoted as $f_0(x', y')$ as in the paragraph before.

Lens plane, just before the lens ($z = F^-$): we apply a Fresnel diffraction (Eq 1.17) between the planes $z = 0$ and $z = F$:

$$f_F(x, y) = e^{ikF} f_0(x, y) * D_F(x, y) \quad (2.18)$$

Focal plane, $z = 2F$: we can apply the result of the paragraph above (Eq. 2.16), the amplitude $f_F(x, y)$ plays here the same role as f_0 in Eq. 2.16:

$$f_{2F}(x, y) = \frac{e^{ikF}}{i\lambda F} e^{\frac{i\pi\rho^2}{\lambda F}} \hat{f}_F\left(\frac{x}{\lambda F}, \frac{y}{\lambda F}\right) \quad (2.19)$$

using the expression of $f_F(x, y)$ we have

$$f_{2F}(x, y) = \frac{e^{ikF}}{i\lambda F} e^{\frac{i\pi\rho^2}{\lambda F}} \mathcal{F}\left[e^{ikF} f_0(x, y) * D_F(x, y)\right]_{u=\frac{x}{\lambda F}, v=\frac{y}{\lambda F}} \quad (2.20)$$

which gives

$$f_{2F}(x, y) = \frac{e^{2ikF}}{i\lambda F} e^{\frac{i\pi\rho^2}{\lambda F}} \hat{f}_0\left(\frac{x}{\lambda F}, \frac{y}{\lambda F}\right) \cdot \hat{D}_F\left(\frac{x}{\lambda F}, \frac{y}{\lambda F}\right) \quad (2.21)$$

The Fourier transform of D_F is $\hat{D}_F(u, v) = \exp[-i\pi\lambda F(u^2 + v^2)]$. It simplifies with the curvature phase term $e^{\frac{i\pi\rho^2}{\lambda F}}$, and we finally obtain

$$\boxed{f_{2F}(x, y) = \frac{e^{2ikF}}{i\lambda F} \hat{f}_0\left(\frac{x}{\lambda F}, \frac{y}{\lambda F}\right)} \quad (2.22)$$

The phase curvature $e^{\frac{i\pi\rho^2}{\lambda F}}$ has now been cancelled and we obtain the exact Fourier transform of the amplitude f_0 of the object, scaled by a factor $\frac{1}{\lambda F}$ in both directions x and y . The relation between f_0 and f_{2F} will be denoted as “optical Fourier transform”.

It can be shown that these results remain valid whatever the position of the object before the lens, providing that the lens is large enough to collect all the light diffracted by the object. Moving the object along the z axis changes only the phase curvature term in Eq. 2.16 but the intensity remains the same.

In the case where the object is placed after the lens, in the converging light beam, one still observes its 2D Fourier transform but there is a scale factor depending on the distance between the lens and the object. We then have a “zoom” effect on the power spectrum by varying the distance.

Chapter 3

Coherent optical filtering

Also read:

- Goodman, J.W., “Introduction to Fourier Optics”, chap 8

3.1 Principle

In electronics, or signal processing, the frequency filtering is the operation which consists to multiply the frequency spectrum of a given temporal signal by a function called “filter”. The result is a convolution of the signal by an impulse response, which is the inverse Fourier transform of the filter. In optics, this operation is made on 2D functions, and is a filtering of *spatial frequencies*.

It is very easy to perform: we showed in section 2.2.2 that a converging lens of focal F forms, in its focal plane, the 2D Fourier transform $\hat{t}\left(\frac{x}{\lambda F}, \frac{y}{\lambda F}\right)$ of an object of transmission $t(x, y)$. It is therefore possible to multiply this Fourier transform by placing objects in the focal plane of the lens. We will denote this focal plane as “filtering plane”, since the filtering is performed in this particular plane. Objects such as slits or diaphragms will act on the modulus of \hat{t} . Transparent objects with a given index of refraction and thickness will act on the phase of \hat{t} .

To observe the result of the filtering in the direct plane, one needs to perform an inverse Fourier transform. In signal processing, this is done by a dedicated software. In optics, one can take advantage of the following remarkable Fourier property:

$$\hat{f}(u, v) \xrightarrow{\mathcal{F}} f(-x, -y) \quad (3.1)$$

hence, a direct Fourier transform is similar to an inverse Fourier transform, with a change of the sign of the variables x and y (resulting in a 180° rotation of the function f). This property allows to observe the result of an optical filtering by placing a second lens after the filtering plane: in the focal plane of this second lens one observes the 2D inverse Fourier transform of the filtered spectrum \hat{t} , i.e. the filtered object, rotated by 180° .

This two-lens system is also known as “double diffraction setup” (see Fig. 3.1), each lens performing an optical Fourier transform (analogous to a Fraunhofer diffraction). Note that the two lenses may have different focal lengths, but the filtering plane has to be at the front focal plane of the second lens (conjugated lenses) in order to avoid unwanted phase curvature terms in the optical Fourier transforms.

3.2 Abbe-Porter experiments

Pioneering experiments were made in the early 1900’s and give a spectacular illustration of image formation and Fourier optics fundamentals. They consist in simple filtering of spatial frequencies, as described in the previous section. The principle is the following: a fine 2D metallic grid is lit by a laser beam (Fig. 3.2). This object is placed at the front focal plane of the first lens (plane P_0). In the filtering plane (P_1) one observes the Fourier transform of the object. It is composed of bright spots (since the object is periodic), every spot being an Airy disc if the grid is limited by a circular diaphragm. In the focal plane of the second lens (observation plane, P_2), one observes a replica of the object, convoluted by the PSF of the filter (see section 3.3 for details). If no filter is placed in the filtering plane, the image is identical to the object (rotated by 180°).

In the filtering plane, bright spots along the horizontal (resp. vertical) axis correspond to horizontal (resp. vertical) spatial frequencies composing the object. We suppose that the filter is here a slit which selects one row of bright spots. If the slit is vertical (Fig. 3.3a) it selects only the vertical frequencies of the object: the image in the plane P_2 is a grid with horizontal parallel strips. If the slit is horizontal, (Fig. 3.3b) horizontal frequencies are selected and the image is composed of vertical parallel strips.

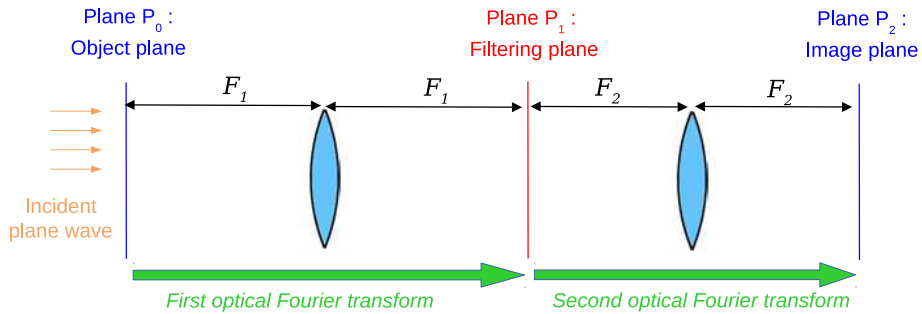

Figure 3.1: Double diffraction setup for optical filtering. The object is placed at the front focal plane of the first lens of focal F_1 and lit by a plane wave. The second lens (focal F_2) is placed at a distance $z = F_1 + F_2$ from the first one, so that the filtering plane is at the front focal plane of the second lens. The observation is made in the back focal plane of the second lens.

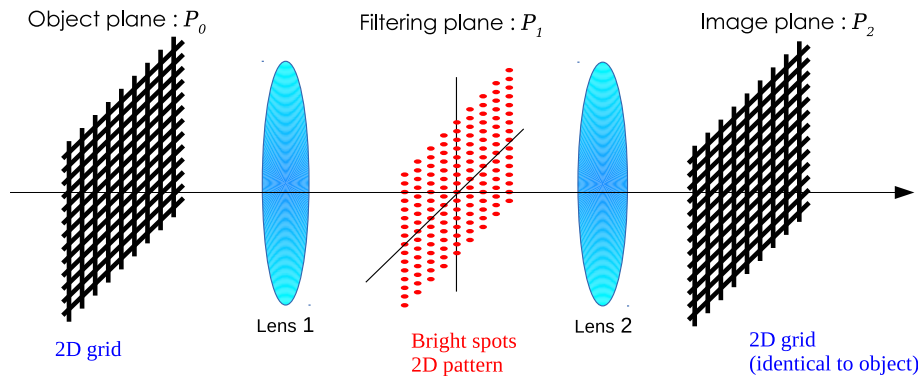

Figure 3.2: Illustration of the Abbe-Porter experiment. A 2D grid is placed in the front object plane P_0 of the first lens. In the focal plane P_1 , one finds the spectrum of the grid, composed of a 2D arrangement of bright spots. If no filter is placed in P_1 , then the second lens forms; at its focal plane P_2 , a replica of the object, rotated by 180° (Fourier transform of its spectrum).

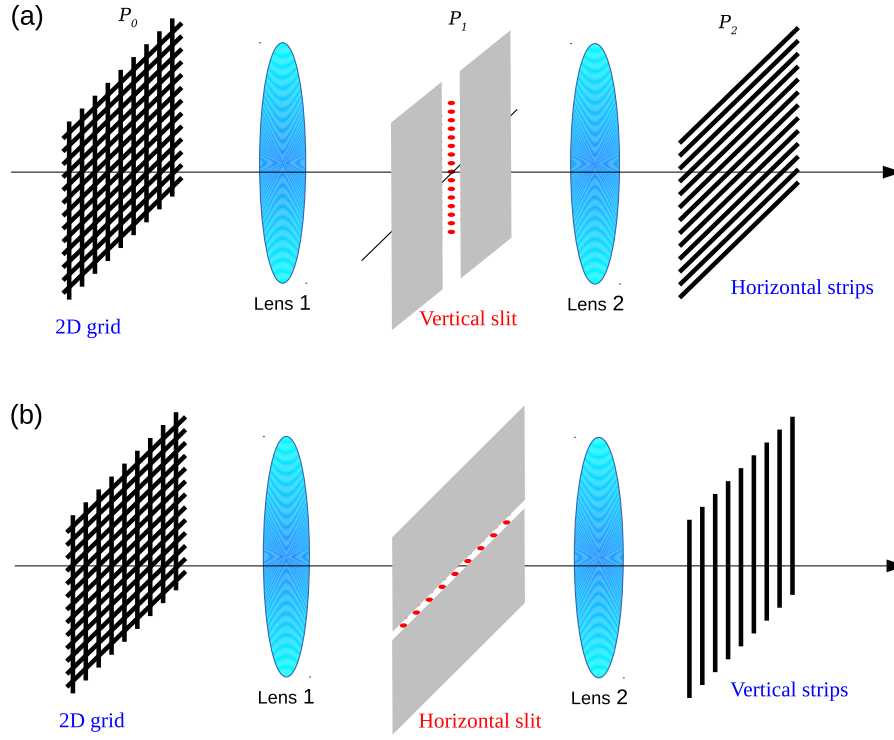

Figure 3.3: Abbe-Porter experiment similar to Fig. 3.2, with a slit in the filtering plane P_1 . (a) vertical slit, selecting the central column of bright spots. The corresponding image in the plane P_2 is a series of horizontal strips, Fourier Transform of the truncated spectrum. (b) horizontal slit, producing in P_2 a set of vertical strips.

3.3 Object-image relation

We consider the double diffraction experiment of Fig. 3.1. The aim of this section is to explicit the relations between the complex amplitudes of the object (plane P_0) and the image in the plane P_2 . We denote as

- ψ_0 the complex amplitude of the incident plane wave in the plane P_0 (normal incidence is assumed)
- F_1 and F_2 the focal length of the two lenses
- (x', y') , (x_1, y_1) and (x, y) the coordinates of a point in the planes P_0 (object plane), P_1 (filtering plane) and P_2 (observation plane)
- $t(x', y')$ the transmission coefficient of the object (plane P_0)
- $P(x_1, y_1)$ the transmission coefficient of the filter (plane P_1)

Let's calculate step by step the propagation from planes P_0 to P_2 : at the output the plane P_0 , the complex amplitude is simply proportional to the transmission of the object:

$$f_0(x', y') = \psi_0 t(x', y') \quad (3.2)$$

We can apply Eq. 2.22 to write the amplitude in the plane P_1 , taking advantage of the Fourier property of the converging lens:

$$f_1(x_1, y_1) = \frac{e^{2ikF_1}}{i\lambda F_1} \hat{f}_0 \left(\frac{x_1}{\lambda F_1}, \frac{y_1}{\lambda F_1} \right) \quad (3.3)$$

In the plane P_1 , the filtering operation is performed by multiplying $f_1(x_1, y_1)$ by the transmission of the filter:

$$f_{1+}(x_1, y_1) = \frac{e^{2ikF_1}}{i\lambda F_1} \hat{f}_0 \left(\frac{x_1}{\lambda F_1}, \frac{y_1}{\lambda F_1} \right) P(x_1, y_1) \quad (3.4)$$

And to obtain the amplitude in the plane P_2 , we make use, once again, of Eq. 2.22:

$$f_2(x, y) = \frac{e^{2ikF_2}}{i\lambda F_2} \hat{f}_{1+} \left(\frac{x}{\lambda F_2}, \frac{y}{\lambda F_2} \right) \quad (3.5)$$

with

$$\hat{f}_{1+} \left(\frac{x}{\lambda F_2}, \frac{y}{\lambda F_2} \right) = \frac{e^{2ikF_1}}{i\lambda F_1} \mathcal{F} \left[\hat{f}_0 \left(\frac{x_1}{\lambda F_1}, \frac{y_1}{\lambda F_1} \right) P(x_1, y_1) \right]_{u=\frac{x}{\lambda F_2}, v=\frac{y}{\lambda F_2}} \quad (3.6)$$

We eventually obtain a convolution relation:

$$f_2(x, y) = -\frac{1}{G} e^{2ik(F_1+F_2)} f_0 \left(-\frac{x}{G}, -\frac{y}{G} \right) * \frac{1}{(\lambda F_2)^2} \hat{P} \left(\frac{x}{\lambda F_2}, \frac{y}{\lambda F_2} \right) \quad (3.7)$$

where $G = \frac{F_2}{F_1}$ is a magnification factor. The amplitude of the final image in the plane P_2 is thus a convolution between $f_0 \left(-\frac{x}{G}, -\frac{y}{G} \right)$ (the object magnified by a factor G and rotated 180°) and the point-spread function $\frac{1}{(\lambda F_2)^2} \hat{P} \left(\frac{x}{\lambda F_2}, \frac{y}{\lambda F_2} \right)$. The magnification applies before the convolution by the impulse response. The case of identical lenses ($F_1 = F_2$) corresponds to $G = 1$: no magnification, the object and image have the same size.

3.4 Low-pass and high-pass filters

In signal processing, low-pass or high-pass filters attenuate low or high frequencies. The spectrum of the signal is multiplied by a function (denoted as *transfer function*) which vanishes for high (resp. low) frequencies in the case of a low-pass (resp. high-pass) filter.

In optics, with a double diffraction experiment, the spectrum of the image can be obtained by taking the Fourier transform of Eq. 3.7. For a sake of simplicity, we shall consider the case of two identical lenses ($F_1 = F_2 = F$). We obtain:

$$\hat{f}_2(u, v) = -e^{4ikF} \hat{f}_0(-u, -v) P(-\lambda Fu, -\lambda Fv) \quad (3.8)$$

The minus sign in both $\hat{f}_0(-u, -v)$ and $P(-\lambda Fu, -\lambda Fv)$ is due to the 180° rotation of the image. The above equation may be rewritten in the following form

$$\hat{f}_2(-u, -v) = -e^{4ikF} \hat{f}_0(u, v) P(\lambda Fu, \lambda Fv) \quad (3.9)$$

which lets appear the product between the object spectrum $\hat{f}_0(u, v)$ and the following transfer function:

$$h(u, v) = P(\lambda Fu, \lambda Fv) \quad (3.10)$$

which is simply a replica of the pupil function, magnified by a factor $\frac{1}{\lambda F}$.

3.4.1 Low-pass filters

A low-pass filter has a transfer function which vanishes for high frequencies. A circular diaphragm of diameter d , centered on the optical axis in the filtering plane, is an example of low-pass filter. The corresponding transfer function is

$$h(u, v) = \prod \left(\frac{\lambda F q}{d} \right) \quad \text{with } q^2 = u^2 + v^2 \quad (3.11)$$

This transfer function is isotropic, and vanishes for spatial frequencies $q > f_c$ with $f_c = \frac{d}{2\lambda F}$ the *cutoff frequency*.

Let's consider the case where the object is a sinusoidal grid of spatial frequency m whose transmission (between 0 and 1) is

$$t(x, y) = \frac{1}{2} + \frac{1}{2} \cos(2\pi mx) \quad (3.12)$$

its Fourier transform is composed of 3 Dirac peaks centered at frequencies $(0, 0)$, $(m, 0)$ and $(-m, 0)$

$$\hat{t}(u, v) = \frac{1}{2} \delta(u, v) + \frac{1}{4} \delta(u - m, v) + \frac{1}{4} \delta(u + m, v) \quad (3.13)$$

Multiplying this spectrum by the transfer function of Eq. 3.11 will cut the lateral peaks if $m > f_c$. In this case, the image in the plane P_2 will be uniform. This is illustrated by Fig. 3.4. For a more general object $t(x, y)$ having a continuous frequency spectrum $\hat{t}(u, v)$, a low-pass filter will remove high frequencies, resulting into a fuzzy image with a loss of details, as illustrated by Fig. 3.5.

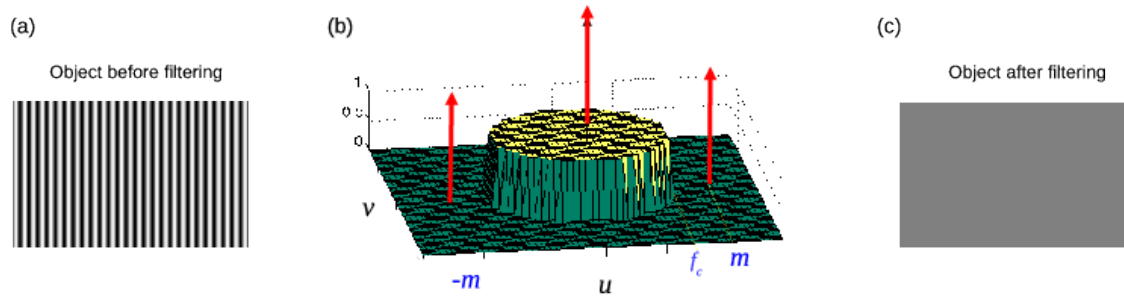

Figure 3.4: Low-pass filtering of a sinusoidal grid of spatial frequency m by a circular transfer function of cutoff frequency $f_c < m$ (see § 3.4.1). (a) grayscale plot of the transmission of the object. (b) Perspective plot showing the transfer function (Eq. 3.11) and the 3 peaks of the Fourier transform of the object (Eq. 3.13). Since $m > f_c$ the two lateral peaks are cut by the transfer function. (c) Resulting image (uniform) in the observation plane P_2 .

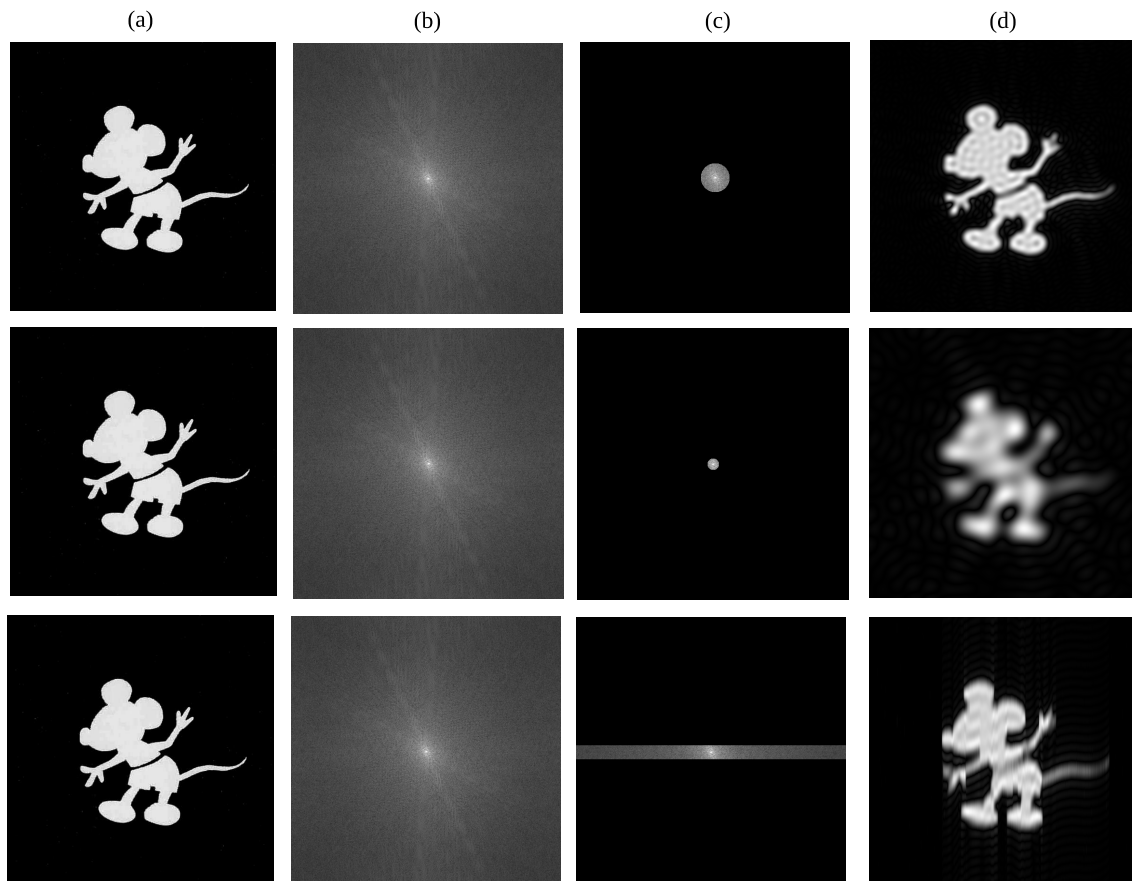

Figure 3.5: Low-pass filtering of an object (Mickey shape) for 3 different filters. (a) Object. (b) Spectrum of the object (modulus). (c) Spectrum of the object (modulus) multiplied by the transfer function of the filter. (d) Resulting image in the observation plane (without the 180° rotation). 1st row: the filter is a circular pupil. 2nd row: the filter is also a circular pupil, but with lower diameter (resulting in a more fuzzy resulting image). 3rd row: the filter is an horizontal slit; it is still a low-pass filter, but in the vertical direction only.

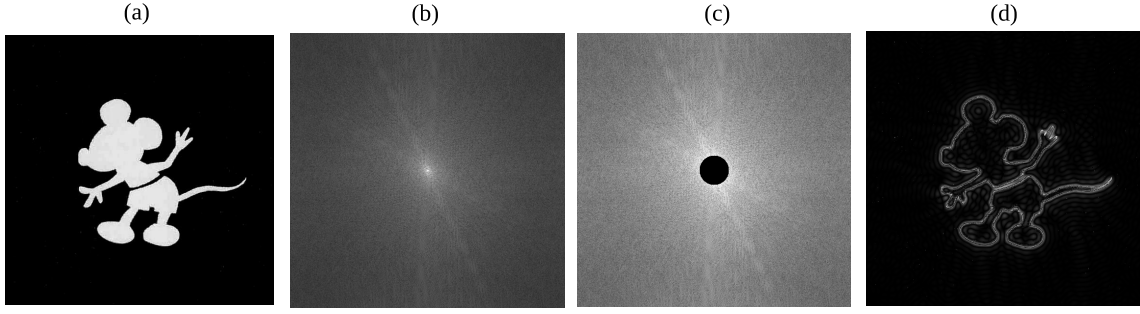

Figure 3.6: High-pass filtering of an object (Mickey shape). (a) Object. (b) Spectrum of the object (modulus). (c) Spectrum of the object (modulus) multiplied by the transfer function of the filter. (d) Resulting image in the observation plane (without the 180° rotation). The filter is here a circular occulter having the same diameter as the circular hole of the 1st row of Fig. 3.5.

3.4.2 High-pass filters

A high-pass filter has a transfer function which vanishes for low frequencies. An example is a on-axis circular occulter of placed in the filtering plane P_1 which blocks the light up to a certain distance from the center. This kind of filter tends to reinforce high spatial frequencies in the image and to emphasize fine details – exactly the opposite of the low-pass filter.

Fig. 3.6 shows the effect of a high-pass filtering by a circular occulter on a “Mickey” object similar to the figure 3.5. The filtered image displays only the contours of Mickey, everything else has been removed by the filter. This reinforcement of the contours is easy to understand if one remarks that the filter (circular occulter) is the complementary screen of a circular diaphragm. Its transmission expresses as

$$P_o(x, y) = 1 - P(x, y) \quad (3.14)$$

with $P(x, y) = \Pi\left(\frac{\rho}{a}\right)$ the transmission of the circular diaphragm. Therefore the point-spread function of the filtering (appearing in Eq. 3.7) is

$$\hat{P}_o\left(\frac{x}{\lambda F}, \frac{y}{\lambda F}\right) = (\lambda F)^2 \delta(x, y) - \hat{P}\left(\frac{x}{\lambda F}, \frac{y}{\lambda F}\right) \quad (3.15)$$

and the amplitude in the observing plane, given by Eq. 3.7, expresses as the difference of two terms

$$f_2(x, y) = -e^{4ikF} \left[\underbrace{f_0(-x, -y)}_{\text{amplitude of the unfiltered object}} - \underbrace{f_0(-x, -y) * \frac{1}{(\lambda F)^2} \hat{P}\left(\frac{x}{\lambda F}, \frac{y}{\lambda F}\right)}_{\text{low-pass filtered object}} \right] \quad (3.16)$$

The first term is the amplitude of the unfiltered object, i.e. the “Mickey” object (Fig. 3.5, column a). The second term is the amplitude of object filtered by the circular diaphragm, it is a smoothed version of “Mickey” (Fig. 3.5, 1st row, column d). The first term has sharpest contours than the second, this is why their difference let only appear only the contours of the object.

Other spectacular illustrations of optical filtering of 2D objects can be found in the book “Atlas of Optical Transforms” by Harburn.

3.5 Strioscopy and phase contrast

Optical filtering techniques can be applied to phase objects, i.e. transparent objects with variable thickness or refraction index (for example a fingerprint on a microscope plate). Phase variations of the object can be made visible by placing an appropriate mask in the filtering plane of a double-diffraction setup.

For the whole paragraph, we consider the optical setup of Fig. 3.1, with identical lenses ($F_1 = F_2 = F$). The object in the plane P_0 is a pure phase object of transmission

$$t(x, y) = e^{i\phi(x, y)} \quad (3.17)$$

lit by an incident plane wave of amplitude ψ_0 . With the condition $\phi(x, y) \ll 1$ (small phase variations), the transmission can be approximated to the first-order development

$$t(x, y) \simeq 1 + i\phi(x, y) \quad (3.18)$$

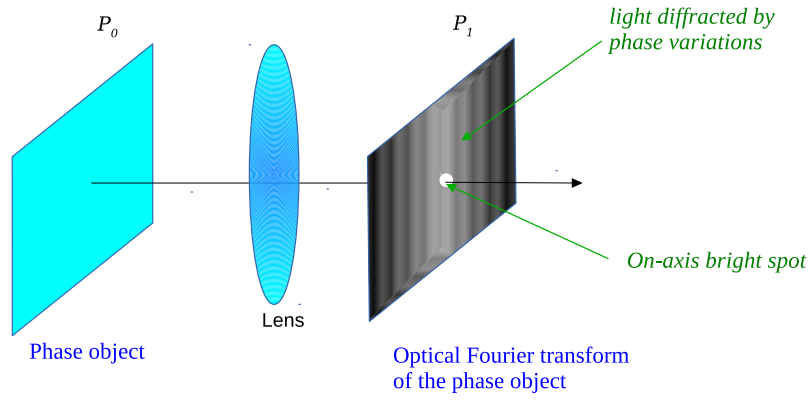

Figure 3.7: Optical Fourier transform of a phase object with small phase variations. The complex amplitude in the focal plane of the lens (P_1) shows a bright central spot surrounded by a halo of light diffracted by phase variations of the object (see Eq. 3.19).

The complex amplitude in the plane P_1 , given by Eq. 3.3, is composed of two terms:

$$f_1(x_1, y_1) = \psi_0 \frac{e^{2ikF}}{\lambda F} \left[\underbrace{-i(\lambda F)^2 \delta(x_1, y_1)}_{\text{bright central spot}} + \underbrace{\hat{\phi}\left(\frac{x_1}{\lambda F}, \frac{y_1}{\lambda F}\right)}_{\text{light diffracted by phase variations}} \right] \quad (3.19)$$

There is a bright spot at the origin, surrounded by a halo of light diffracted by the phase variations $\phi(x, y)$ of the object. This halo of light is faint because $\phi(x, y) \ll 1$, and disappears if $\phi = 0$, i.e. if there is no object in the plane P_0 (in this case the bright central spot is simply the light of the incident plane wave, focused by the lens L_1). This is illustrated by Fig. 3.7. If no filter is placed in the plane P_1 , one observes, in the image plane P_2 , a complex amplitude

$$f_2(x, y) = e^{4ikF} \psi_0 t(-x, -y) \quad (3.20)$$

and the intensity is uniform since $|t(-x, -y)|^2 = 1$. This means that the phase variations of the object are invisible on the image. To make them visible, several kinds of filters can be placed in the plane P_1 . We shall study two of them in the following: an amplitude filter (strioscopy technique) and a phase filter (phase-contrast technique).

3.5.1 Strioscopy

In the technique of strioscopy, the filter is a circular occulter of very small diameter (like a pinhead), centered on the optical axis. It is a high-pass filter which blocks only the spatial frequency $(0, 0)$. The optical setup is shown in Fig. 3.8. The action of the occulter is to cancel the Dirac peak appearing in the complex amplitude in the plane P_1 (Eq. 3.19). At the output of the filter, the complex amplitude becomes

$$f_{1+}(x_1, y_1) \simeq \psi_0 \frac{e^{2ikF}}{\lambda F} \hat{\phi}\left(\frac{x_1}{\lambda F}, \frac{y_1}{\lambda F}\right) \quad (3.21)$$

Note that the occulter cancels also a part of the term $\hat{\phi}\left(\frac{x_1}{\lambda F}, \frac{y_1}{\lambda F}\right)$ near the origin, but since we made the hypothesis that the occulter is very small, this effect will be neglected. The complex amplitude in the observation plane P_2 is

$$f_2(x, y) = -i e^{4ikF} \psi_0 \phi(-x, -y) \quad (3.22)$$

and the intensity is

$$I_2(x, y) = |\psi_0|^2 |\phi(-x, -y)|^2 \quad (3.23)$$

it is proportional to the square of the phase variations of the object. Therefore the object phase is made visible by this strioscopy technique. Similar results can be obtained by replacing the occulter in the plane P_1 by a half plane (Foucault knife-edge technique). Spectacular videos can be found on the web, see for example

<https://www.futura-sciences.com/sciences/videos/voir-invisible-strioscopie-822/>.

However this technique has the disadvantage that the sign of the phase is lost (i.e. it is impossible to know if a given structure in the image corresponds to a bump or a hole on the object). Also, since the phase variations $\phi(x, y)$ are small, images are very faint. The alternative technique of “phase contrast”, presented hereafter, provides an answer to these problems.

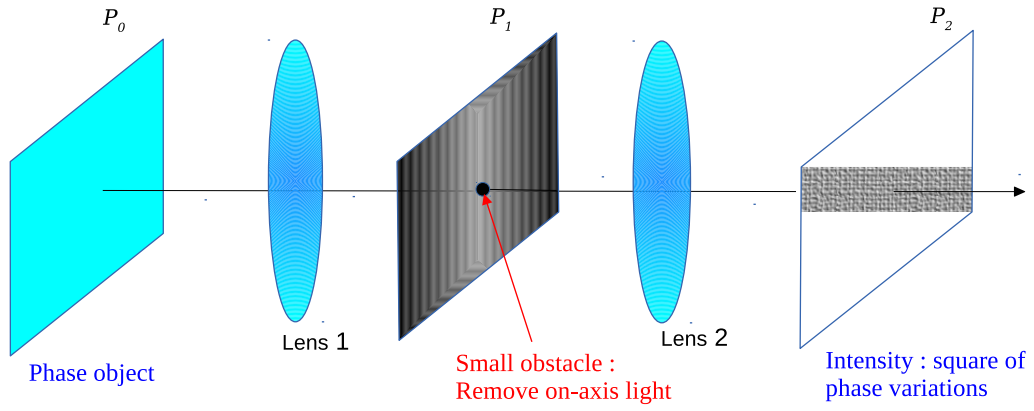

Figure 3.8: Strioscopy technique applied to a phase object placed in the plane P_0 . In the Fourier plane (P_1), there is a central bright spot (see Eq. 3.19) which is cancelled by a small occulter. In the image plane P_2 , the intensity is proportional to the square of the phase variations of the object.

3.5.2 Phase contrast

The technique of phase contrast was proposed by Zernike in the early 30s (Zernike F., 1934, MNRAS 94, 377). It appeared to have many applications in microscopy to study quasi-transparent living cells. Zernike was awarded the Nobel prize in 1953 for the phase-contrast microscopy technique. Phase contrast is similar to strioscopy: the difference is that the occulter is no more opaque, but is a small parallel plate producing a $\frac{\pi}{2}$ phase shift to the on-axis light. The complex amplitude in the plane P_1 at the output of the plate becomes

$$f_{1+}(x_1, y_1) = \psi_0 \frac{e^{2ikF}}{\lambda F} \left[(\lambda F)^2 \delta(x_1, y_1) + \hat{\phi} \left(\frac{x_1}{\lambda F}, \frac{y_1}{\lambda F} \right) \right] \quad (3.24)$$

and in the observation plane

$$f_2(x, y) = -i e^{4ikF} \psi_0 [1 + \phi(-x, -y)] \quad (3.25)$$

The corresponding intensity is (under the hypothesis $\phi(x, y) \ll 1$)

$$I_2(x, y) \simeq |\psi_0|^2 [1 + 2\phi(-x, -y)] \quad (3.26)$$

it is now an affine function of the phase $\phi(x, y)$, composed of a constant term (uniform light background) and intensity variations proportionnal to the phase of the object, with its sign: brightest (resp. darkest) zones in the image correspond to positive (resp. negative) phase value.

Chapter 4

Image formation

Also read : Goodman J.W., ‘Introduction to Fourier Optics”, chap. 6

The aim of this chapter is to derive the object-image relation between intensities of an astronomical object and its image at the focus of a telescope. The object is supposed to be incoherent and at large distance from the telescope. The optical scheme is shown hereafter:

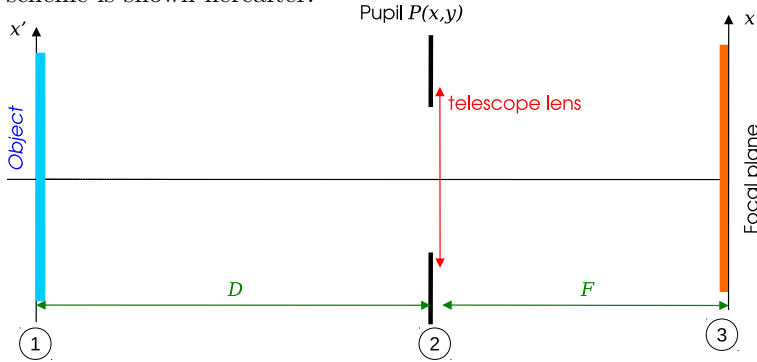

We use the following conventions:

- Plane ①:** Astronomical object (distance from the telescope is D , can be several parsecs)
- Plane ②:** Converging lens (focal F) + pupil function $P(x, y)$ (in most cases a uniform disc)
- Plane ③:** Image plane = focal plane of the telescope.

Principle of the calculation:

- Place a point-source at position (x_0, y_0) in plane ①.
- Calculate the corresponding intensity in plane ③, using Fourier properties of lenses
- Sum on (x_0, y_0) to obtain the intensity produced by any object in plane ①.

4.1 Object-image convolution relation

4.1.1 Image created by a point-source

In plane ①

Coordinates the plane ① are denoted as (x', y') . A point-source is placed at position (x_0, y_0) : its complex amplitude is $f_1(x', y') = a_0 \delta(x' - x_0, y' - y_0)$ where a_0 is a constant. We change to the following angular variables

$$\begin{bmatrix} \alpha' = \frac{x'}{D} \\ \beta' = \frac{y'}{D} \end{bmatrix} \quad \begin{bmatrix} \alpha_0 = \frac{x_0}{D} \\ \beta_0 = \frac{y_0}{D} \end{bmatrix} \quad (4.1)$$

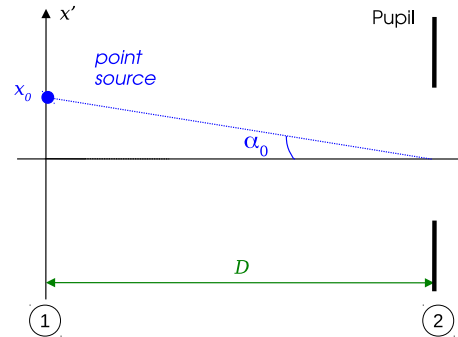

so that the complex amplitude writes as

$$f_1(x', y') = a_0 \delta(x' - x_0, y' - y_0) = \frac{a_0}{D^2} \delta(\alpha' - \alpha_0, \beta' - \beta_0) = f_0 \delta(\alpha' - \alpha_0, \beta' - \beta_0). \quad (4.2)$$

The corresponding intensity is:

$$I_0 \delta(\alpha' - \alpha_0, \beta' - \beta_0) \quad (4.3)$$

with $I_0 = |f_0|^2$

In plane ②

Since D is very large (astronomical distance), Fraunhofer diffraction is assumed between planes ① and ②. Therefore the complex amplitude in plane ②, just before the telescope pupil, is

$$f_2(x, y) = \frac{e^{ikD}}{i\lambda D} \hat{f}_1\left(\frac{x}{\lambda D}, \frac{y}{\lambda D}\right) \quad (4.4)$$

with $f_1(x', y') = a_0 \delta(x' - x_0, y' - y_0)$ the complex amplitude of the point-source as a function of linear coordinates x' and y' (not angular, to apply the formula for Fraunhofer diffraction). The calculation gives

$$\begin{aligned} f_2(x, y) &= \frac{e^{ikD}}{i\lambda D} a_0 e^{-\frac{2i\pi}{\lambda D}(xx_0 + yy_0)} \\ &\quad \downarrow \text{change variable } \alpha_0 = x_0/D, \beta_0 = y_0/D \\ &= \frac{e^{ikD}}{i\lambda D} a_0 e^{-\frac{2i\pi}{\lambda}(\alpha_0 x + \beta_0 y)} \\ &= e^{ikD} \frac{Df_0}{i\lambda} e^{-\frac{2i\pi}{\lambda}(\alpha_0 x + \beta_0 y)} \end{aligned} \quad (4.5)$$

We recognise the complex amplitude of a plane wave with angles of incidence $(-\alpha_0, -\beta_0)$. This is expected, since a point-source emits a spherical wave which becomes plane at large distance.

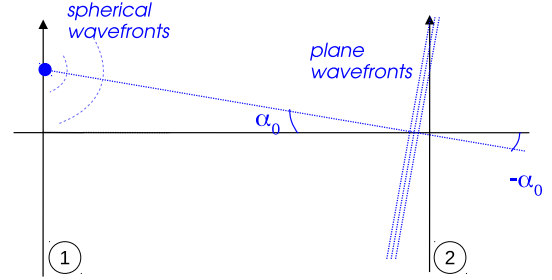

The complex amplitude just after the pupil is

$$f_{2+}(x, y) = e^{ikD} \frac{Df_0}{i\lambda} e^{-\frac{2i\pi}{\lambda}(\alpha_0 x + \beta_0 y)} P(x, y) \quad (4.6)$$

In plane ③

The complex amplitude just before the telescope lens is $f_{2+}(x, y)$. Therefore the complex amplitude at the focal plane is (see Section 2.2.2, Eq. 2.16):

$$f_3(x, y) = \frac{e^{ikF}}{i\lambda F} \exp\left(\frac{i\pi\rho^2}{\lambda F}\right) \hat{f}_{2+}\left(\frac{x}{\lambda F}, \frac{y}{\lambda F}\right) \quad (4.7)$$

with $\rho^2 = x^2 + y^2$. We get:

$$f_3(x, y) = -\frac{e^{ik(F+D)}}{\lambda^2} \frac{Df_0}{F} \exp\left(\frac{i\pi\rho^2}{\lambda F}\right) \mathcal{F}\left[e^{-\frac{2i\pi}{\lambda}(\alpha_0 x + \beta_0 y)} P(x, y)\right] \quad (4.8)$$

where the Fourier Transform above (\mathcal{F}) is to be taken for variables $u = \frac{x}{\lambda F}$ and $v = \frac{y}{\lambda F}$. Here we have

$$\mathcal{F}\left[e^{-\frac{2i\pi}{\lambda}(\alpha_0 x + \beta_0 y)} P(x, y)\right] = \hat{P}\left(u + \frac{\alpha_0}{\lambda}, v + \frac{\beta_0}{\lambda}\right) \quad (4.9)$$

so

$$\begin{aligned}
 f_3(x, y) &= -\frac{e^{ik(F+D)}}{\lambda^2} \frac{Df_0}{F} \exp\left(\frac{i\pi\rho^2}{\lambda F}\right) \hat{P}\left(\frac{x}{\lambda F} + \frac{\alpha_0}{\lambda}, \frac{y}{\lambda F} + \frac{\beta_0}{\lambda}\right) \\
 &\quad \downarrow \text{change variable } \alpha = x/F, \beta = y/F \\
 &= -\frac{e^{ik(F+D)}}{\lambda^2} \frac{Df_0}{F} \exp\left(\frac{i\pi\rho^2}{\lambda F}\right) \hat{P}\left(\frac{\alpha + \alpha_0}{\lambda}, \frac{\beta + \beta_0}{\lambda}\right)
 \end{aligned} \tag{4.10}$$

The variables α and β represent angles in the image plane as seen from the center of the pupil.

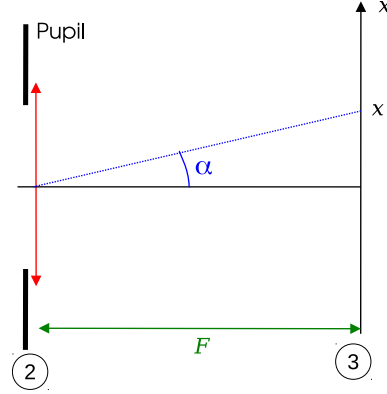

The intensity is $|f_3|^2$. Using angular variables (α, β) , it expresses as

$$|f_3(\alpha, \beta)|^2 = K I_0 \left| \hat{P}\left(\frac{\alpha + \alpha_0}{\lambda}, \frac{\beta + \beta_0}{\lambda}\right) \right|^2 \tag{4.11}$$

where $K = \frac{D^2}{\lambda^4 F^2}$ is a multiplicative constant, generally neglected. We introduce

$$S(\alpha, \beta) = \left| \hat{P}\left(\frac{\alpha}{\lambda}, \frac{\beta}{\lambda}\right) \right|^2 \tag{4.12}$$

so that the intensity is simply $I_0 S(\alpha + \alpha_0, \beta + \beta_0)$ (neglecting the constant K). As a conclusion, we can see that a point-source at position (angle) (α_0, β_0) in plane ① produces an image whose intensity is the Fourier Transform (square modulus) of the pupil function, centered at position $(-\alpha_0, -\beta_0)$. This is illustrated by the following scheme:

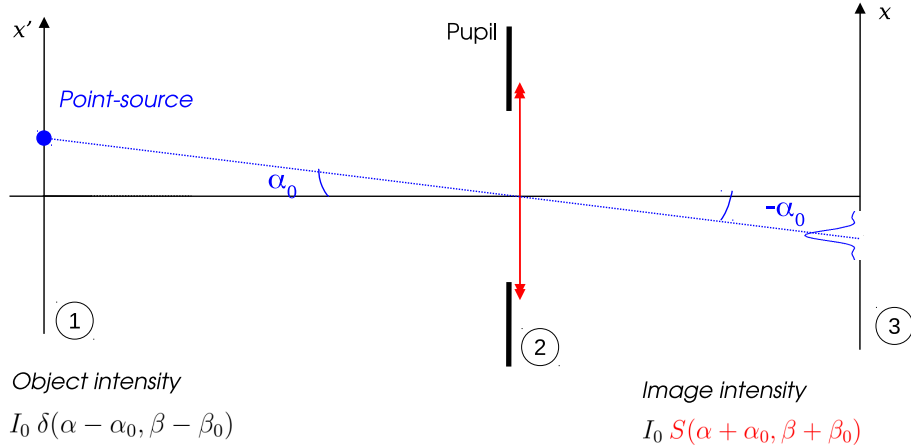

Point-Spread Function: The quantity $S(\alpha, \beta)$ is called the *Point-Spread Function* (PSF). It is indeed the image of a point-source of unit intensity ($I_0 = 1$) located on the optical axis ($\alpha_0 = \beta_0 = 0$). It expresses as the power spectrum (square modulus of the Fourier Transform) of the pupil function, as defined in Eq. 4.12

4.1.2 Object-image relation

In plane ① we now consider an *incoherent* object with intensity distribution $I_0(\alpha', \beta')$ as a function of position angles defined by Eq. 4.1. The intensity I_0 can be written as

$$I_0(\alpha', \beta') = I_0 * \delta(\alpha', \beta') = \iint_{-\infty}^{\infty} \underbrace{I_0(\alpha_0, \beta_0)}_{\text{weighting factor}} \underbrace{\delta(\alpha' - \alpha_0, \beta' - \beta_0)}_{\text{unit point-source}} d\alpha_0 d\beta_0 \tag{4.13}$$

This integral can be interpreted as a continuous sum of point-sources located at positions (α_0, β_0) and weighted by the factor $I_0(\alpha_0, \beta_0)$. Each of these point-sources produces in the plane ③ a PSF $S(\alpha + \alpha_0, \beta + \beta_0)$, weighted by the same factor, as demonstrated in previous section. Thus the total intensity observed at plane ③ is the continuous sum of intensities¹ produced by each point-source, i.e.

$$\begin{aligned}
 I(\alpha, \beta) &= \iint_{-\infty}^{\infty} I_0(\alpha_0, \beta_0) S(\alpha + \alpha_0, \beta + \beta_0) d\alpha_0 d\beta_0 \\
 &\quad \downarrow \text{change variable } \alpha' = -\alpha_0, \beta' = -\beta_0 \\
 &= \iint_{-\infty}^{\infty} I_0(-\alpha', -\beta') S(\alpha - \alpha', \beta - \beta') d\alpha' d\beta'
 \end{aligned} \tag{4.14}$$

And we obtain the well-known *object-image convolution relation* between intensities, expressed with angular variables:

$$\boxed{I(\alpha, \beta) = I_0(-\alpha, -\beta) * S(\alpha, \beta)} \tag{4.15}$$

The function $I_0(-\alpha, -\beta)$ represents the object rotated by 180°. This relation is valid only for incoherent sources (a similar relation exists between amplitudes for coherent light, see for example the chapter 5 of Goodman, Introduction to Fourier Optics).

Geometric limit, infinite pupil: this is the case where $P(x, y) = 1$. The lens in plane ② has no spatial limitation. The PSF is then a Dirac impulse:

$$S(\alpha, \beta) = \delta(\alpha, \beta) \tag{4.16}$$

so the image of a point-source is a single point (perfect stigmatism): this is the case of geometric optics. Note that the same result is obtained if $\lambda \rightarrow 0$. The object-image relation becomes

$$I(\alpha, \beta) = I_0(-\alpha, -\beta) \tag{4.17}$$

so the image is the object itself (rotated by 180°).

4.2 Optical transfer function (OTF)

The convolution relationship in the focal plane (Eq. 4.15) corresponds to a linear filtering in the Fourier plane. If we denote u and v the *angular* frequencies associated with α and β , the Fourier transform of Eq. 4.15 becomes

$$\hat{I}(u, v) = \hat{I}_0(-u, -v) \cdot T(u, v) \tag{4.18}$$

with

$$T(u, v) = \mathcal{F}[S(\alpha, \beta)] = \mathcal{F}\left[\left|\hat{P}\left(\frac{\alpha}{\lambda}, \frac{\beta}{\lambda}\right)\right|^2\right] \tag{4.19}$$

The function $T(u, v)$ is called “Optical transfer function” (OTF). It is a complex function; its modulus and phase are denoted as “modulation transfer function” and “phase transfer function” respectively. u and v are expressed in rad^{-1} . To calculate $T(u, v)$, we use the Wiener-Kinchin theorem, which expresses the Fourier transform of the power spectrum of a function:

$$\mathcal{F}[|\hat{f}(u)|^2] = C_f(X) = \int_{-\infty}^{\infty} f(x) \overline{f(x+X)} dx \tag{4.20}$$

The quantity $C_f(X)$ is the *Autocorrelation function* of $f(x)$. It can be interpreted as the integral of superposition of the function $f(x)$ and the same function conjugated and translated: $\overline{f(x+X)}$.

Proof of the Wiener-Kinchin theorem:

- Write $|\hat{f}(u)|^2 = \hat{f}(u) \cdot \overline{\hat{f}(u)}$

¹To calculate the intensity created by the addition of several waves in incoherent light, one adds *intensities* of individual waves (not amplitudes).

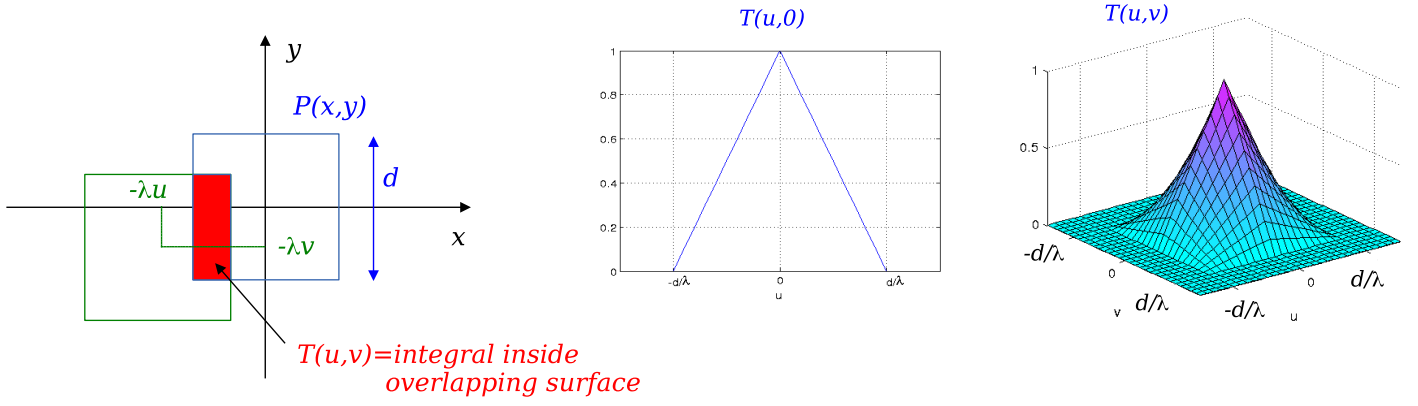

Figure 4.1: Illustration of the calculation of an Optical transfer function in the case of a square pupil of side d . Left: superposition of the overlapping terms: $P(x,y)$ (centered at $(0,0)$) and $P(x+\lambda u, y+\lambda v)$ (centered at $(-\lambda u, -\lambda v)$) which intervene in the integral of Eq. 4.26. Middle and right: plot of the OTF for $v=0$ and in the (u,v) plane. The OTF is a pyramid in this case.

- Use the following Fourier properties :

$$\mathcal{F}[\hat{f}(u)] = f(-X) \quad (4.21)$$

and

$$\mathcal{F}[\overline{f(x)}] = \widehat{\hat{f}(-u)} \quad (4.22)$$

- The Fourier transform of $|\hat{f}(u)|^2$ is obtained as the convolution

$$C_f(X) = f(-X) * \overline{f(X)} \quad (4.23)$$

which develops as

$$C_f(X) = \int_{-\infty}^{\infty} f(-x') \overline{f(X-x')} dx' = \int_{-\infty}^{\infty} f(x) \overline{f(x+X)} dx \quad (4.24)$$

To compute the optical transfer function, we make use of the Wiener-Kinchin theorem and the Fourier property

$$\mathcal{F}\left[f\left(\frac{x}{a}\right)\right] = |a| \hat{f}(au)$$

so that

$$T(u,v) = \mathcal{F}\left[\left|\hat{P}\left(\frac{\alpha}{\lambda}, \frac{\beta}{\lambda}\right)\right|^2\right] = \lambda^2 C_P(\lambda u, \lambda v) \quad (4.25)$$

and in general we introduce a multiplicative constant to normalise the transfer function so that $T(0,0) = 1$. We shall then define the OTF as

$$T(u,v) = \frac{1}{S} C_P(\lambda u, \lambda v) = \frac{1}{S} \iint_{-\infty}^{\infty} P(x,y) \overline{P(x+\lambda u, y+\lambda v)} dx dy \quad (4.26)$$

where S is the surface of the pupil. This is the integral of superposition of two identical pupils, one being conjugated and shifted by a quantity $(-\lambda u, -\lambda v)$ as illustrated by Fig. 4.1

Properties of the OTF:

- It is a normalised function $T(0,0) = 1$
- It is an hermitian function: $T(-u, -v) = \overline{T(u,v)}$
- If the pupil $P(x,y)$ is real, then the OTF $T(u,v)$ is **real and even**, $T(-u, -v) = T(u,v)$
- If the pupil is a separable function $P(x,y) = P_1(x).P_2(y)$ then the OTF is also a separable function $T(u,v) = \frac{1}{S} C_{P_1}(\lambda u).C_{P_2}(\lambda v)$
- If the pupil is isotropic (i.e. $P(x,y) = P(\rho)$ with $\rho^2 = x^2 + y^2$) then the OTF is also isotropic ($T(u,v) = T(q)$ with $q^2 = u^2 + v^2$)

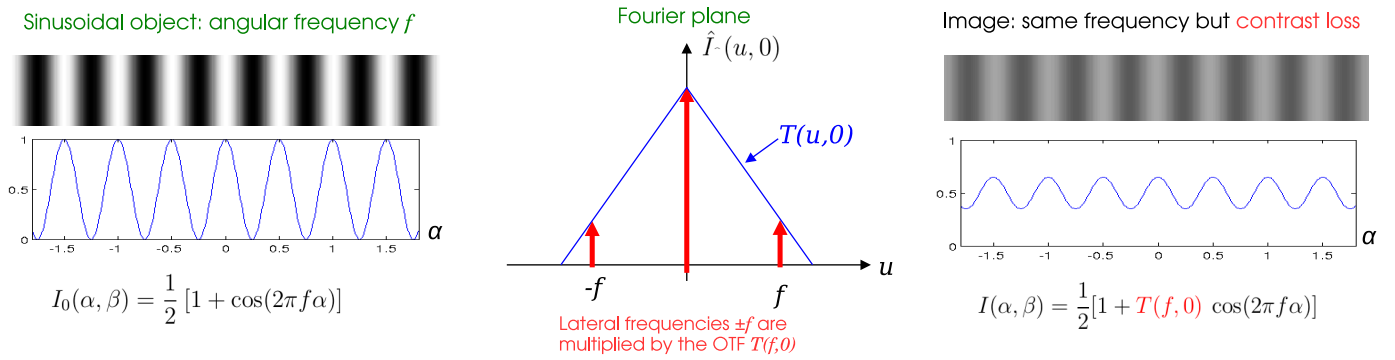

Figure 4.2: Illustration of the physical significance of the OTF in the case of an image of a sinusoidal grid. Left: object of intensity $I_0(\alpha, \beta)$. Middle: Fourier transform $\hat{I}(u, 0)$ together with the OTF $T(u, 0)$ (taken as a triangle for this example). Right: Observed image, with a contrast $|T(f, 0)|$.

Physical significance of the transfer function: To understand the physical significance of the OTF, let's consider an incoherent object which is a pure sinusoidal grid of angular frequency f in the α direction, as in Fig. 4.2. The object has an intensity distribution

$$I_0(\alpha, \beta) = \frac{1}{2} [1 + \cos(2\pi f\alpha)] \quad (4.27)$$

This object has indeed 3 vector angular frequencies in the (u, v) plane: $\vec{f}_1 = (0, 0)$, $\vec{f}_2 = (f, 0)$ and $\vec{f}_3 = (-f, 0)$. Its Fourier transform is

$$\hat{I}_0(u, v) = \frac{1}{2}\delta(u, v) + \frac{1}{4}\delta(u - f, v) + \frac{1}{4}\delta(u + f, v) \quad (4.28)$$

Applying the object-image relation in the Fourier plane (Eq. 4.18), we can derive the F.T. of the intensity distribution of the image:

$$\hat{I}(u, v) = \frac{T(0, 0)}{2}\delta(u, v) + \frac{T(f, 0)}{4}\delta(u - f, v) + \frac{T(-f, 0)}{4}\delta(u + f, v) \quad (4.29)$$

With $T(0, 0) = 1$ by definition. The lateral terms in $\hat{I}(u, v)$ are multiplied by *the value of the OTF at (u, v) equals to the grid frequencies*. In the case of an even OTF (corresponding to square or a circular pupil), we have $T(f, 0) = T(-f, 0)$ and the expression simplifies. It is then easy to obtain the image intensity distribution by inverse F.T.:

$$I(\alpha, \beta) = \frac{1}{2} [1 + T(f, 0) \cos(2\pi f\alpha)] \quad (4.30)$$

Which is also a sinusoidal grid of same frequency as the object. The difference is that the cosine term has been attenuated. The contrast of this figure is

$$C = \frac{I_{\max} - I_{\min}}{I_{\max} + I_{\min}} = |T(f, 0)| \quad (4.31)$$

which gives the physical significance of the OTF, in fact of its modulus (the MTF): it is indeed the contrast (also known as "visibility") of the image of the grid. Changing the grid frequency would result into another value of the contrast. It is then possible to estimate the MTF by making images of grids of various frequencies and measure their contrast.

4.3 Case of a circular pupil

4.3.1 PSF and resolving power

The pupil is a uniform disc of diameter d . It expresses as

$$P(x, y) = \Pi\left(\frac{\rho}{d}\right) \quad \text{with } \rho^2 = x^2 + y^2 \quad (4.32)$$



the PSF is an Airy disc of intensity

$$S(\alpha, \beta) = \left(\frac{\pi d^2}{4}\right)^2 4 \text{jinc}\left(\frac{\pi d\theta}{\lambda}\right)^2 \quad (4.33)$$

it is an isotropic function of the angle $\theta^2 = \alpha^2 + \beta^2$. It is independent of the telescope focal. The multiplicative constant $\left(\frac{\pi d^2}{4}\right)^2$ may be omitted. The PSF is displayed in Fig. 4.3. It exhibits a central peak of angular radius $1.22\frac{\lambda}{d}$ surrounded by dark and bright faint rings (the brightest ring has a maximum intensity of 1.7% of the peak intensity of the PSF).

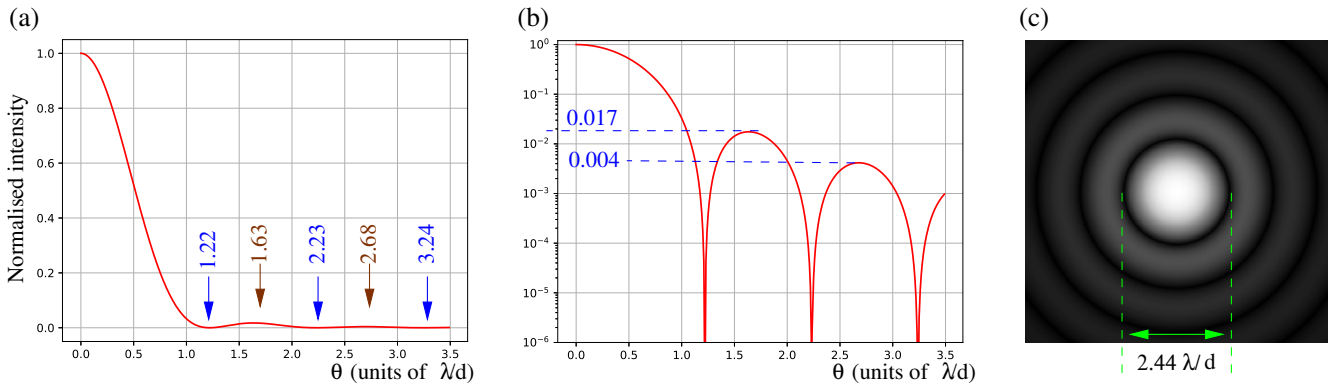

Figure 4.3: Airy disc: intensity PSF for a circular pupil of diameter d (Eq. 4.33). (a) plot of the intensity profile as a function of position angle θ in the focal plane. Positions of the first zeros and the first secondary maxima are written on the graph (in units of λ/d). (b) Same plot in semi-log scale. Relative intensities of the first secondary maxima are written on the graph. (c) Gray-level plot of the Airy disc.

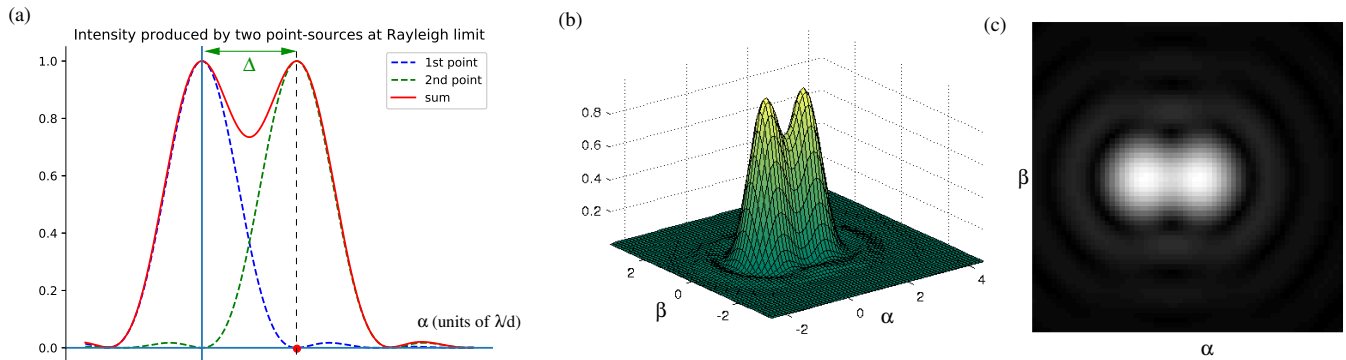

Figure 4.4: Image of two point-sources by a circular pupil at Rayleigh limit: star separation Δ is equal to the PSF radius $= 1.22\lambda/d$. (a) Plot of the intensity as a function of the angle α in the focal plane. (b) Surface plot of the intensity $I(\alpha, \beta)$. (c) Gray level plot of the intensity showing the aspect of the image.

Resolving power: it is defined from the image of two point-sources, composed by the sum of two shifted PSF. Images of each point-source are distinct if their separation is greater than the size of the PSF. An empiric definition was proposed by Lord Rayleigh in 1879 (*Phil. Mag. S 5. Vol. 8, Oct. 1879*). It corresponds to the situation where the angular separation Δ of the two points is exactly equal to the PSF radius, i.e. the radius of the first dark ring of the Airy disk (see Fig 4.4):

$$\Delta = 1.22 \frac{\lambda}{d} \quad [\text{unit: radian}] \quad (4.34)$$

Typical values for $\lambda = 500$ nm:

- $d = 12$ cm $\implies \Delta = 1$ arcsec
- $d = 2$ mm (human eye in daylight) $\implies \Delta = 1$ arcmin
- $d = 2.40$ m (Hubble Space Telescope) $\implies \Delta = 0.05$ arcsec

4.3.2 Optical transfer function

The OTF $T(u, v)$ is the surface of the intersection of two discs of diameter d , shifted by a vector $(\lambda u, \lambda v)$ as defined by Eq. 4.26. It is a real, isotropic function. The calculus is made in a geometrical way (see Goodman, “Introduction to Fourier Optics” for details) and gives a *chinese hat* function (or, more simply, a “hat function”).

$$T(u, v) = \text{大} \left(\frac{\lambda q}{d} \right) \quad \text{with} \quad q^2 = u^2 + v^2 \quad (4.35)$$

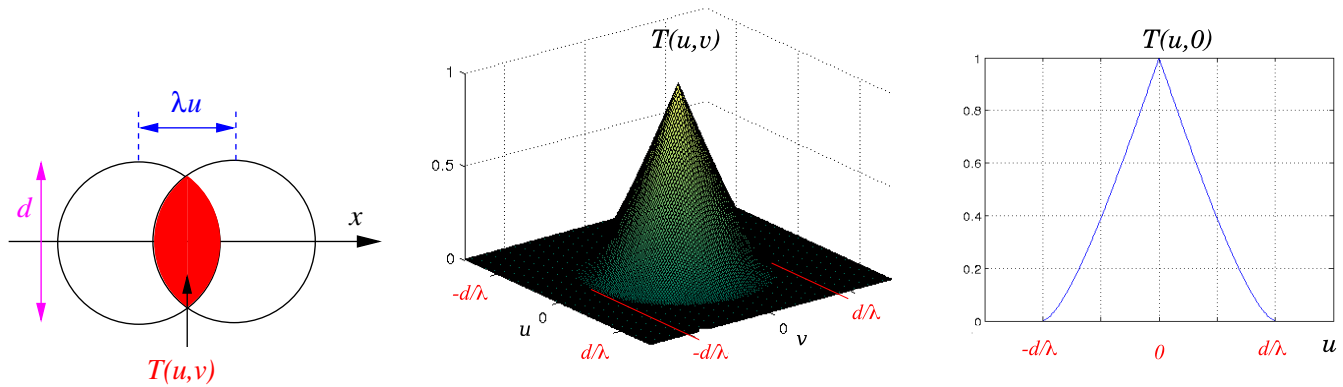
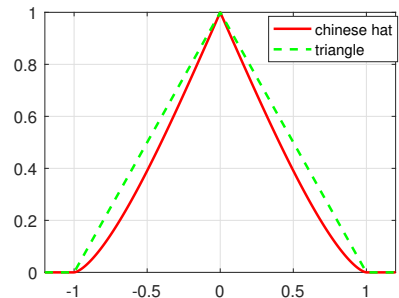

Figure 4.5: Transfer function of a circular pupil. Left: geometric interpretation of $T(u, v)$ as the area of the intersection of two identical shifted pupils (Eq. 4.26). Middle: 3D plot of the OTF showing the typical “chinese hat” shape. Right: Plot of $T(u, 0)$, showing the angular cutoff frequency $f_c = d/\lambda$.

where

$$\text{大}(x) = \frac{2}{\pi} \left[\arccos(|x|) - |x| \sqrt{1 - x^2} \right] \quad (4.36)$$

The function $\text{大}(x)$ is displayed on the right: it looks like a triangle with curved sides. It is an even function, vanishing for $|x| \geq 1$.



The graph of the transfer $T(u, v)$ function is shown in Fig. 4.5. It is an isotropic hat function which has non-zero values for $q \leq \frac{d}{\lambda}$. It corresponds to a low-pass filtering of angular frequencies of the object.

Cutoff frequency: it is defined as the highest frequency for which the transfer function is not zero. For a circular pupil of diameter d , the angular cutoff frequency is

$$f_c = \frac{d}{\lambda} \quad \text{unit: rad}^{-1} \quad (4.37)$$

The cutoff frequency is the frequency of the finest sinusoidal grid that the telescope is capable to image with non-zero contrast. In other words, if one considers an pure sinusoidal object having an intensity distribution $I_0(\alpha, \beta) = A \cos(\pi u_0 \alpha)^2$ of angular frequency u_0 , then its image becomes uniform when $u_0 \geq d/\lambda$.

It is possible to use f_c to define a resolving power in a sense less empirical than the Rayleigh criterion presented before. Let's define $\Delta_c = \frac{1}{f_c}$ the *cutoff period*, i.e. the angular period of the finest imageable grid. Indeed, Δ_c represents the angular size of the finest details in the image: this gives another definition of the resolving power for a pupil of diameter d :

$$\Delta_c = \frac{\lambda}{d} \quad (4.38)$$

It is sometimes called “**resolution element**” or *resel*. We see that Δ_c is close to the Rayleigh definition $\Delta = 1.22 \frac{\lambda}{d}$. Note that

- When $d \nearrow$ then $\Delta_c \searrow$: better resolution for a large telescope
- When $\lambda \searrow$ then $\Delta_c \searrow$: better resolution at short wavelengths

Chapter 5

Exercises

0 Exercises for chapter 0

0.1 1-dim Fourier transforms

1. Use the Fourier formula sheet to calculate the Fourier Transform (FT) of the function $f(x) = a + b \cos(2\pi u_0 x)$ (a, b, u_0 are positive numbers). Compare with the FT of the function $f(x) = a + b \sin(2\pi u_0 x)$ (make a plot of both Fourier transforms).
2. Consider the function $f(x) = \Pi\left(\frac{x}{a}\right) \cdot \cos(2\pi u_0 x)$ with $u_0 \gg \frac{1}{a}$ and Π the rectangular function. Plot f (take for example $u_0 = \frac{4}{a}$), and calculate its FT $\hat{f}(u)$. Plot \hat{f} .
3. Consider the function $f(x) = \Pi\left(\frac{x - \frac{a}{2}}{b}\right) + \Pi\left(\frac{x + \frac{a}{2}}{b}\right)$ with $a > b$. Plot f . Express it as a convolution, calculate its Fourier Transform $\hat{f}(u)$, and plot the graph of \hat{f} for $a = 4b$.
4. Consider the Ronchi function defined as $f(x) = \Pi\left(\frac{x}{a}\right) * \text{III}_{2a}(x)$ where III_a is the Dirac comb of period a . Plot its graph, calculate and plot its Fourier transform. What happens to \hat{f} if one multiplies f by a rectangular function $\Pi\left(\frac{x}{L}\right)$ with $L = 10a$?
5. Let g_a the centered Gaussian function of standart deviation $a > 0$, defined as

$$g_a(x) = \frac{1}{a\sqrt{2\pi}} e^{-\frac{x^2}{2a^2}}$$

Show that $g_a * g_b = g_{\sqrt{a^2+b^2}}$, where $*$ is the convolution product (hint: do the calculation in the Fourier plane).

0.2 2-dim Fourier transforms

1. Calculate the Fourier transform (FT) of the 2-dimensionnal rectangle function of width a in the x direction b in the y direction. The rectangle is supposed centered at the origin. Plot \hat{f} in the case $b = 2a$
- 2.

Consider the function

$$f(x, y) = \begin{cases} \cos^2(\pi x/a) & \text{if } \sqrt{x^2 + y^2} < \frac{d}{2}. \\ 0 & \text{otherwise} \end{cases}$$

with $d \gg a > 0$. Express f using the rectangular function, calculate and plot its Fourier transform.

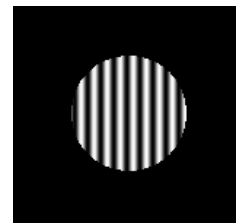

- 3.

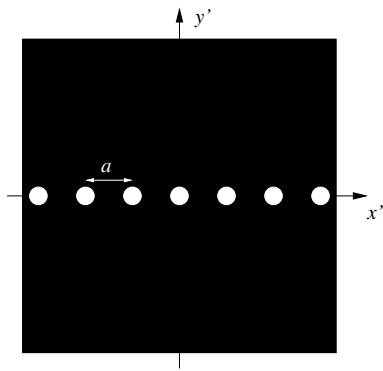

The function on the left is composed of an infinity of identical circular pupils of diameter d , regularly placed along the x axis with a period $a > d$. Calculate and plot its Fourier transform

4. Show that the 2-dimensional FT of a circularly symmetric function $f(\rho)$ with $\rho^2 = x^2 + y^2$ is the Hankel transform (*Hint: write the 2D Fourier integral, and express it in polar coordinates*).

$$\hat{f}(u, v) = \int_0^\infty f(\rho) J_0(2\pi q\rho) 2\pi\rho d\rho$$

with $q^2 = u^2 + v^2$. The function $J_0(x) = \frac{1}{2\pi} \int_0^{2\pi} e^{ix \cos \theta} d\theta$ is the Bessel function of order 0. We recall that $\cos(a-b) = \cos a \cos b + \sin a \sin b$.

5. Use the Hankel transform to calculate the FT of a circular pupil $f(\rho) = \Pi(\frac{\rho}{d})$ with $\rho^2 = x^2 + y^2$ and $d > 0$ the pupil diameter. Express it with the jinc function defined as $\text{jinc}(x) = \frac{J_1(x)}{x}$ where J_1 is the 1st order Bessel function (we recall the useful formula : $(x^n J_n(x))' = x^n J_{n-1}(x)$). Plot f .

1 Exercises for chapter 1

1.1 Fresnel diffraction of elementary waves

We consider monochromatic waves of wavelength λ and study their propagation under paraxial approximation, using the Fresnel diffraction.

1. Recall the amplitude PSF $D_z(x, y)$ of the Fresnel diffraction and calculate its Fourier transform $\hat{D}_z(u, v)$ (this quantity is called the “transfer function”).
2. Using the transfer function, show that a plane wave (consider normal incidence) of amplitude ψ_0 remains plane after propagation on a distance z .
3. Using the transfer function, show that a diverging spherical wave (in paraxial approximation) with source at position $(0, 0, -z_s)$ (with $z_s > 0$ and $z_s \gg x, y$) remains spherical after propagation from the plane $z = 0$ to a plane $z > 0$.

1.2 Fresnel diffraction of of a periodic pattern — Talbot effect

A monochromatic wave has an amplitude $f_0(x, y) = A(1 + \epsilon \cos(2\pi \frac{x}{a}))$, in the plane $z = 0$, with ϵ, a positive numbers and A a complex constant.

1. Use the Fresnel transfer function $\hat{D}_z(u, v)$ to write the amplitude at a distance z of the screen.
2. With the condition $\epsilon \ll 1$, write down the corresponding intensity.
3. Show the existence of planes $z = z_p$ where the intensity is identical to the intensity in the plane $z = 0$ just after the screen (this phenomenon is known as “Talbot effect”). Calculate the distance z_T between successive Talbot planes.
4. What do we see in planes $z = z_T/4, z = z_T/2$ and $z = 3z_T/4$?

1.3 Fresnel diffraction by a circular aperture

A circular aperture of diameter d is lit by a plane wave of wavelength λ , the amplitude in the plane $z = 0$ is $f_0(x, y) = \psi_0 \Pi(\frac{\rho}{d})$ with $\rho = (x^2 + y^2)^{1/2}$. The aim of the exercise is to show that the intensity at the center of the diffraction pattern is zero for particular values of z . Paraxial approximation is assumed in the whole problem.

1. Recall the relation between amplitudes $f_0(x, y)$ and $f_z(x, y)$ in the planes $z = 0$ and z . For what follows, we set $x = y = 0$ (optical axis). Expand the convolution to obtain the amplitude $f_z(0, 0)$ as a 2D integral.
2. The function $f_0(x, y)$ has circular symmetry and depends only of ρ (radial function). Change coordinates to obtain a 1D integral form of the amplitude $f_z(0, 0)$ in polar coordinates.
3. Calculate the integral (it's analytic), and write the on-axis intensity $I_z(0, 0)$ as a function of z .
4. Show that the intensity is zero for specific values z_p of z . Plot the graph of $I_z(0, 0)$ as a function of z .

1.4 The Moon laser at the Plateau de Calern

The Moon laser, located on the Plateau de Calern, allows to estimate the distance between the Earth and the Moon. The principle is the following: a laser beam is emitted from a 1.5m telescope at Calern. On the Moon, small mirrors were installed by astronauts (Apollo missions) and reflect a part of the beam towards the Earth. Since the speed of light is very well known, the round-trip propagation time of the laser light gives the Earth-Moon distance.

The laser beam exiting the telescope is modelled by a monochromatic plane wave (wavelength λ and amplitude A). The telescope pupil is circular (diameter d). The wave propagates over a distance D to attain the Moon.

1. We call W the electromagnetic power of the laser beam. Express W as a function of A (hint: consider the intensity of the wave).
2. Using Fraunhofer approximation, write down the diffracted amplitude at a distance D from the telescope pupil. On the Moon, what is the diameter \mathcal{L}_1 of the first dark Airy ring? N.A.: $d = 1.5$ m, $D = 384000$ km, $\lambda = 0.5$ μm .
3. Give the complex amplitude ψ_0 and the intensity I_0 at the centre of the diffraction pattern (on the Moon). Express I_0 as a function of W (calculated in question 1).
4. The reflector on the Moon is supposed to be a circular mirror of diameter $a \ll \mathcal{L}_1$ (with a reflection coefficient of 100%). It is located at the center of the Airy disc of the telescope, and, since its diameter is small, uniformly lit. Give the expression of the electromagnetic power W_1 reflected by the mirror and calculate numerically the ratio W_1/W for $a = 3\text{cm}$.
5. After being reflected, the wave propagates back towards the earth (distance D). What is the size \mathcal{L}_2 of the diffraction pattern on the Earth (diameter of the first dark Airy disc)? Give its numeric value. What is the intensity at the center of the Airy disc?
6. Assuming $d \ll \mathcal{L}_2$, give the total electromagnetic power collected by a telescope of diameter d located at the center of the diffraction pattern of the returning beam. Calculate the efficiency (ratio W_2/W of the collected/emitted wave) of the Moon Laser.

1.5 Aperture synthesis

We consider an opaque screen pierced with N circular holes of diameter d centered at positions $\vec{\rho}_k$. This screen is lit under normal incidence by a plane wave of wavelength λ and amplitude ψ_0 . We want to calculate the diffracted amplitude at some distance z , under Fraunhofer approximation, as a function of angles α and β .

1. Consider $N = 2$, $\vec{\rho}_1 = (\frac{a}{2}, 0) = -\vec{\rho}_2$ with $a = 10d$. Write down the expression for the diffracted intensity, and calculate the angular fringe size and the angular diameter of the first Airy disc. Plot the two-dimensional intensity using your computer.
2. Consider $N = 3$ apertures at the vertices of an equilateral triangle of side $a = 10d$. Show that the intensity exhibits three fringe patterns corresponding to the 3 hole pairs (give the period and the direction of these fringe patterns). Plot the two-dimensional intensity.
3. Consider $N = 10$ apertures regularly placed along a circle of diameter $a = 10d$. Plot the two-dimensional intensity and compare it with the intensity diffracted by a circular pupil of diameter a .

1.6 Circular pupil with central obstruction

We consider a circular aperture of diameter d with a central circular obstruction of diameter d_1 . The aperture is lit under normal incidence by a plane wave of wavelength λ .

Circular pupil with central obstruction

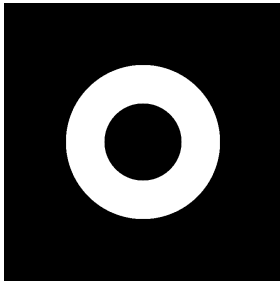

x	$\text{jinc}(\pi x)$	x	$\text{jinc}(\pi x)$	x	$\text{jinc}(\pi x)$	x	$\text{jinc}(\pi x)$	x	$\text{jinc}(\pi x)$
0.0	0.500	1.0	0.090	2.0	-0.033	3.0	0.018	4.0	-0.012
0.1	0.493	1.1	0.045	2.1	-0.019	3.1	0.011	4.1	-0.007
0.2	0.475	1.2	0.006	2.2	-0.004	3.2	0.003	4.2	-0.002
0.3	0.446	1.3	-0.023	2.3	0.008	3.3	-0.004	4.3	0.003
0.4	0.407	1.4	-0.046	2.4	0.019	3.4	-0.011	4.4	0.007
0.5	0.360	1.5	-0.059	2.5	0.026	3.5	-0.016	4.5	0.010
0.6	0.308	1.6	-0.065	2.6	0.031	3.6	-0.019	4.6	0.013
0.7	0.252	1.7	-0.064	2.7	0.032	3.7	-0.020	4.7	0.014
0.8	0.196	1.8	-0.058	2.8	0.030	3.8	-0.019	4.8	0.013
0.9	0.141	1.9	-0.047	2.9	0.025	3.9	-0.016	4.9	0.011

Table of values of the function $\text{jinc}(\pi x)$

- Using the Fraunhofer approximation, calculate the amplitude $f(\alpha, \beta)$ as a function of the angles α and β .
- Calculate the intensity I_0 at the center of the diffraction pattern as a function of the ratio d_1/d
- For what follows we shall suppose $d_1/d = 0.5$. Using either your computer or the table above, plot each of the two terms of the amplitude as a function of α .
- Give the radius of the 1st dark ring (amplitude is zero). How does it compare with the situation without obstruction ?
- Estimate the intensity I_1 at the maximum of the 1st bright ring (consider that the radius of the first bright ring is the same as the situation without obstruction). Compare it with the value corresponding to the unobstructed aperture. Do the same for the 2nd and 3rd bright rings.

More information at : <http://www.telescope-optics.net/obstruction.htm>

1.7 Fraunhofer diffraction by a screen

- Consider a screen of transmission $t(\rho) = \alpha\delta(\rho - d/2)$ with $\rho^2 = x^2 + y^2$ and d a positive number. What does this screen look like ?
- The screen is lit under normal incidence by a plane wave of complex amplitude A . Use Fraunhofer approximation to calculate the amplitude diffracted by this screen at a distance z (*Hint: make use of the Hankel transform*).
- With your computer, plot the intensity diffracted by the above screen, and compare it with the intensity diffracted by an unobstructed circular aperture of diameter d . In particular compare the radii of the central peaks and the intensities at the maximum of the first bright rings.

1.8 Fraunhofer diffraction by a 2D periodic pattern

We consider a bidimensional periodic grid of transmission $t_1(x, y) = \sin^2(\pi \frac{x}{a}) \cos^2(\pi \frac{y}{a})$. The grid is spatially limited by a circular diaphragm of diameter $D \gg a$.

The mask is in the plane $z = 0$. It is illuminated under normal incidence by a monochromatic plane wave of wavelength λ and amplitude ψ_0 . We observe the diffraction pattern in a plane $z > 0$.

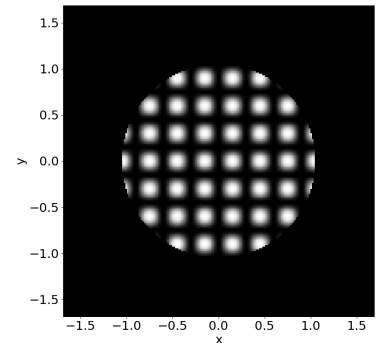

- Write down the transmission $t(x, y)$ of the mask (including the diaphragm)

- Write the complex amplitude of the wave at the mask output (plane $z = 0^+$)
- We observe the diffraction pattern at a distance z from the mask. What is the condition on z to be in the far-field domain (Fraunhofer diffraction)?
- Calculate the amplitude $f_z(x, y)$ diffracted by this screen (Fraunhofer diffraction)
- Plot the amplitude $f_z(x, 0)$ (neglect multiplicative constant in factor). Put on your graph all relevant informations and characteristic values
- Describe the 2D image in the (x, y) plane (you can make a drawing). How many spots are visible?

1.9 Bright filament

In the plane $z = 0$, we consider a mask with a transmission coefficient $t(x', y') = \epsilon \delta(x')$ (independent of y') where ϵ is a positive real number. This screen, placed in the $z = 0$ plane, is illuminated normal incidence by a plane wave with amplitude A in the mask plane, propagating towards $z > 0$. The wavelength is λ . We are operating under paraxial optics conditions.

- Why do we talk about a “light filament”? Answer in a few sentences (one may consider the intensity at the mask output).
- What is the dimension (unit) of ϵ (and why)?
- Write the complex amplitude $f_0(x', y')$ at $z = 0^+$.
- Write the complex amplitude $f_D(x, y)$ for $z = D$ in the form of a convolution (Fresnel diffraction).
- Calculate $f_D(x, y)$.
- Which variable does $f_D(x, y)$ not depend on? What type of wave is this?
- Write the phase $\phi(x, y)$ of the wave.
- Calculate the intensity $I_D(x, y)$.

Now we add the light from the filament with that of a plane wave with normal incidence and amplitude $B e^{-i\pi/4}$ in the $z = 0$ plane (same wavelength).

- Write, in the $z = D$ plane, the resulting complex amplitude from the interference of this plane wave with f_D .
- Calculate the corresponding intensity in the case where A and B are real and $|B| \gg \frac{\epsilon}{\sqrt{\lambda D}} |A|$.
- Give the positions of the intensity maxima and minima.
- Calculate the contrast of $I(x, 0)$.
- Plot the graph of the intensity $I(x, 0)$ as a function of x .
- Show that this technique allows obtaining (possibly up to a constant) the phase $\phi(x, y)$ of the wave f_D (it is called “holography”, the image in the $z = D$ plane is a hologram).

2 Exercises for chapter 2

2.1 Measuring the focal length of a telescope

Accurate estimation of the focal of a telescope is a crucial step to calibrate the field of view of a focal instrument (e.g. camera). The focal length can be measured by placing a periodic mask (grating) of known period at the entrance pupil of the telescope. The image of a star is then a succession of peaks whose separation is proportional to the focal length. We used this technique in 2005 on the 102cm telescope of Merate (Italy) and built the mask of the photo on the right. (Scardia et al., 2007, MNRAS **374**, 965).

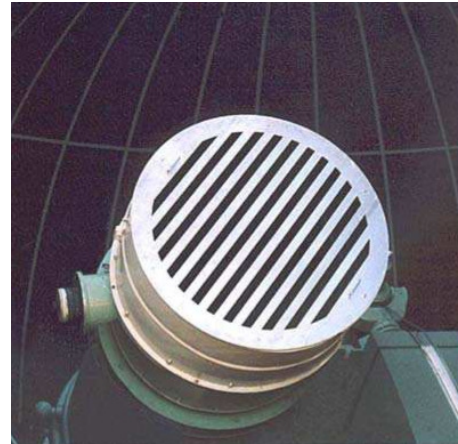

For this problem we consider mask periodic along the x direction, whose transmission is described by the sinusoidal function $t(x) = \cos^2\left(\frac{\pi x}{a}\right)$. It is spatially limited by the telescope pupil, i.e. a disc of diameter $d \gg a$. Values for Merate are: $d = 102\text{cm}$, $a = 88\text{mm}$. The mask looks like the image on the right.

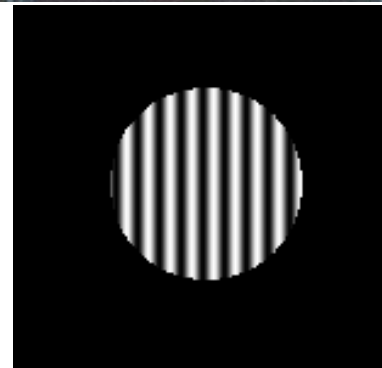

1. Write the transmission coefficient of the mask (including the telescope pupil).
2. The mask is placed at the front focal plane of the telescope (considered as a thin lens of focal F). The incident light is a plane wave of wavelength λ having a constant amplitude A on the telescope pupil. Write the complex amplitude at the image focal plane.
3. Calculate the positions of the peaks, and their width ℓ
4. Give an approximate expression of the intensity at the focal plane in the case $d \gg a$
5. If the position of the peaks is measured with an accuracy $\Delta = \frac{\ell}{10}$, what is the relative error $\frac{\Delta F}{F}$ on the telescope focal for the mask of Merate ($d = 102\text{cm}$, $a = 88\text{mm}$) ?
6. Using your computer, plot the graph of the intensity for $\lambda = 600\text{ nm}$ (take $F = 16\text{m}$).
7. By a simple reasoning, explain how would be modified the image in case of polychromatic light.
8. Plot the graph of the polychromatic intensity (consider uniform spectrum of central wavelength $\lambda = 600\text{ nm}$ and width $\delta\lambda = 50\text{ nm}$ and sample the bandwidth with $N = 10$ values of λ).

2.2 Focusing screens

1. A screen has a transmission $t_0(x, y) = \cos^2\left(\frac{\pi \rho^2}{a^2}\right)$, with a a constant and $\rho^2 = (x^2 + y^2)$. Show that this screen, when lit by a monochromatic plane wave, is equivalent to a combination of two lenses.
2. Show that this screen has focusing properties and give its focal length.
3. Calculate its focal length in the red ($\lambda = 0.7\mu$) and the blue ($\lambda = 0.4\mu$) for $a = 5\text{ mm}$. What would be observed on the optical axis, near the focus, if the mask is lit in white light ?
4. Give the fraction of the incident intensity which is concentrated at the focus (hint: do the calculation in the mask plane).

5. The variable transmissions of such screens is indeed very difficult to manufacture with precision. It is easier to make a screen of binary transmission (1 or 0), as the Soret pattern shown in the figure below (on the left). Its transmission expresses as $t(x, y) = H(\sin(\frac{\pi \rho^2}{a^2}))$ with H the Heaviside unit step. Write down a Fourier-like expansion for t (*Hint: set $X = \rho^2$, plot $t(X)$, express it as a Ronchi function, and perform a Fourier expansion using the Poisson formula.*). Show that this screen act as a sum of converging and diverging lenses, and that it has multiple focal planes.

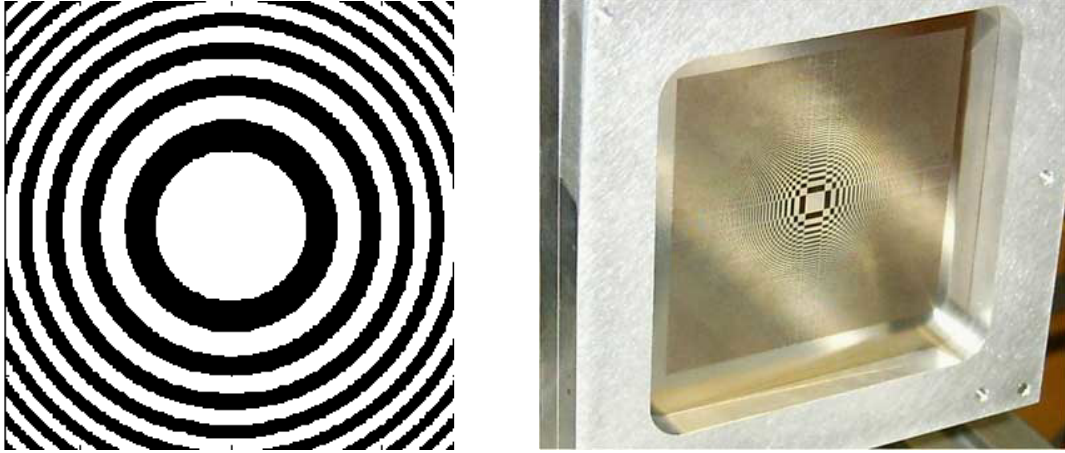

Figure 5.1: Left : ideal Soret grating. Right : prototype installed on the 76cm refractor of Nice observatory. See Serre & Koechlin, EAS Pub. Series, Vol. 22, , pp.253 (2006)

2.3 Diffraction grating

A glass plate of refraction index n has a sinusoidal thickness $e(x, y) = e_0 + e_1 \sin(2\pi \frac{x}{a})$ where e_0 , e_1 and a are positive numbers. It is spatially limited by a square aperture of side $L \gg a$. It is placed in the plane $z = 0$ and lit under normal incidence by a plane wave of wavelength λ and amplitude A . A converging lens of focal F is placed in the plane $z = F$.

1. What are the dimensions (i.e. in which unit are they expressed) of e_0 , e_1 and a (justify your answer) ?
2. Write down the complex transmission $t(x, y)$ of the plate (you may neglect constant phase terms in factor).
3. Use the relation $e^{iX \sin \phi} = \sum_{p=-\infty}^{\infty} J_p(X) e^{ip\phi}$ to calculate the complex amplitude in the focal plane of the lens (J_p denotes the Bessel function of integer order p).
4. Give the position (x_p, y_p) and the width of the diffraction order p
5. In the case $L \gg a$, write an approximate expression of the intensity $I(x, y)$ in the focal plane, and describe the observed figure. Make a plot of $I(x, 0)$
6. Give the ratio R_p between the maximum intensity in the order p and the order 0.
7. Give an approximation of R_p when e_1/λ is weak (use the Taylor approximation $J_p(X) \simeq \frac{1}{p!} (\frac{x}{2})^p$ for $x \rightarrow 0$)
8. What is the condition on e_1/λ to neglect the order $p = 2$ with a glass plate of refraction index $n = 2$ (consider the condition $R_2 < 0.01$) ?

2.4 Cylindrical lens

A cylindrical converging thin lens is a portion of a cylinder of axis Δ , as shown in the figure on the right. As for a spherical lens, its amplitude coefficient transmission $C_F(x, y)$ is a pure phase term (the lens itself being a “phase mask”). We suppose that

$$C_F(x, y) = \exp\left(-\frac{i\pi x^2}{\lambda F}\right) \mathbf{1}(y)$$

where F is the focal of the lens and λ the wavelength. Paraxial approximation is assumed on the whole problem.

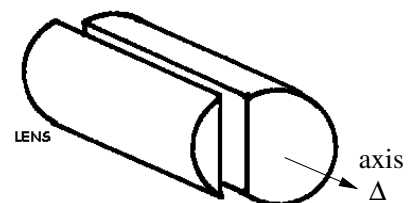

1. Which direction is the axis Δ parallel to (x or y) ? Justify your answer.
2. Show that this cylindric lens is equivalent to the superposition of two masks: a converging (spherical) thin lens $L_F(x, y)$ and a mask $M(x, y)$. Give the expression of $M(x, y)$. What is the nature of optical element corresponding to the mask $M(x, y)$?
3. The lens is placed in the plane $z = 0$. It is lit under normal incidence by a plane wave of amplitude A (in the plane $z = 0$) and wavelength λ . Calculate the complex amplitude in the plane $z = F$ (hint: use the result of question 2). Describe the image in the plane $z = F$ (make a sketch).
4. How is modified the amplitude in the plane $z = F$ if the cylindrical lens is spatially limited by a slit of transmission $\Pi(\frac{x}{d})$? Describe the corresponding image (intensity) and make a sketch.

2.5 Apodized grating

We consider a grating made of very fine slits aligned with the axis y , of period a in the x direction, limited by a square of side $L \gg a$. We place on this grating a plastic film with transmission coefficient $t_p(x) = \Lambda(2x/L)$ (Λ is the triangle function defined as $\Lambda(x) = 1 - |x|$ if $x < 1$ and 0 otherwise). The graph below shows the appearance of this grating as well as a graph of its transmission coefficient for $y = 0$.

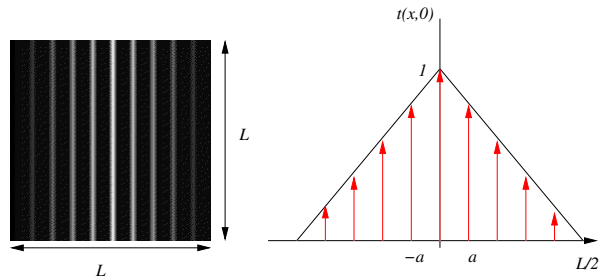

It is placed in the plane $z = 0$, at a distance F from a converging lens of focal F . It illuminated under normal incidence by a plane wave of amplitude ψ_0 and wavelength λ . We observe the image in the focal plane of the lens $z = 2F$.

1. Write down the transmission $t(x, y)$ of the mask (including the square), and the complex amplitude of the wave at the mask output (plane $z = 0^+$) (hint: remark that the product of a triangle $\Lambda(2x/L)$ by a gate of size L is equal to the triangle)
2. Calculate the amplitude $f_{2F}(x, y)$ in the focal plane of the lens
3. What is the position and the width of the order n in the focal plane?
4. Plot the amplitude $f_{2F}(x, 0)$ (neglect multiplicative constant in factor). Put on your graph all relevant informations and characteristic values
5. Describe the 2D image in the (x, y) plane (you can make a drawing).

2.6 Lens lit by a point-source

Consider a point source located at position $(x_0, 0, 0)$ where $x_0 \geq 0$. This source emits a spherical wave with wavelength λ . In the plane $z = p > 0$, there is a converging lens with a focal length of F . We are operating under the conditions of paraxial optics.

1. Write the transmission coefficient of the lens as a function of the coordinates (x, y)
2. Write the complex amplitude at the output of the lens (plane $z = p^+$) when $x_0 = 0$ and $p = F$. Describe this wave (type of wave, direction of propagation, etc.), optionally provide a plot.
3. Assume $p = F$ and $x_0 > 0$.
 - (a) Under what condition on x_0 can we make the paraxial approximation (no proof required)?
 - (b) Write the complex amplitude at the output of the lens (plane $z = p^+$). Describe this wave (type of wave, direction of propagation, etc.), you may make a plot.
4. Assume $x_0 = 0$ and $p > F$.

- Write the complex amplitude at the output of the lens (plane $z = p^+$).
- How can we identify that we are dealing with a spherical wave?
- Is it converging or diverging?
- Identify the position z_s of the center of this wave (its source if the wave is diverging or its convergence point if the wave is converging).
- Let p' denote the quantity $z_s - p$. Relate p' to p and f (we retrieve the well known formula of optical conjugation in geometric optics).

3 Exercises for chapter 3

3.1 Filtering of periodic patterns

The optical setup below is composed of two identical conjugated lenses of focal length $F_1 = 1$ m (Abbe-Porter double diffraction setup). The incident plane wave as a complex amplitude Ae^{ikz} (normal incidence). The object (plane $z = 0$) has a transmission $t(x, y)$. In the filtering plane (focal plane of the lens L_1), there is a circular pupil $P(x, y)$ of diameter D .

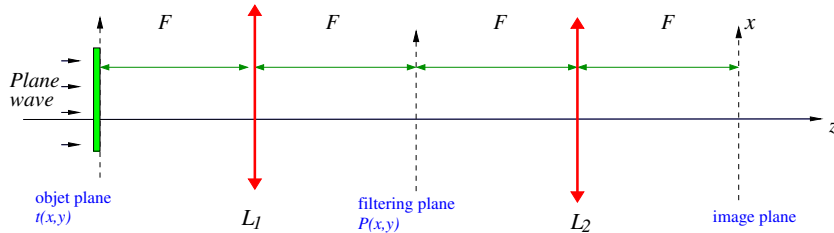

- Write down the complex amplitude in the filtering plane, just after the circular pupil.
- Derive the relation between amplitudes in the object and image planes. Express it as a convolution product with a point-spread function (PSF) (*we recall that $f(\lambda x) * g(\lambda x) = |\lambda| (f * g)(\lambda x)$*).
- If the object has a transmission $t(x, y) = \cos^2(\frac{\pi x}{a})$, what is the condition on D to obtain a uniform image ? Under that condition, compare the period of the object and the PSF size in the image plane and conclude.
- The object is now composed of 6 periodic patterns as in the figure below. Each pattern is described by a \cos^2 function of period $a = 2$ mm, 1.7 mm, 1.5 mm, 1.4 mm, 1.3 mm and 1 mm (*these patterns are actually used in laboratories to measure the resolution of instruments, see http://en.wikipedia.org/wiki/1951_USAF_resolution_test_chart*).

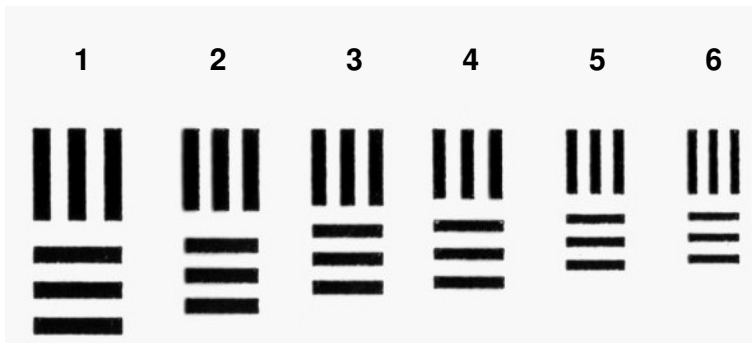

The wavelength is $\lambda = 700$ nm, the observed image (figure below) show that the grids 3 to 6 are uniform. What is the condition on the pupil diameter D to observe this image ? What if the wavelength is set to $\lambda = 500$ nm (using the same pupil diameter as before) ?



5. The object is now a Siemens star (fig. on the right). It has a number N of radial lines over an angle of 2π radians.
 - (a) Express the spatial period as a function of the distance ρ from the star center
 - (b) Describe the image and give the diameter Δ of the disc in which the image is uniform.
 - (c) If L is the star diameter, what is the pupil diameter to realise $\Delta = L/2$? N.A.: $\lambda = 600$ nm, $N = 36$, $L = 1$ cm.

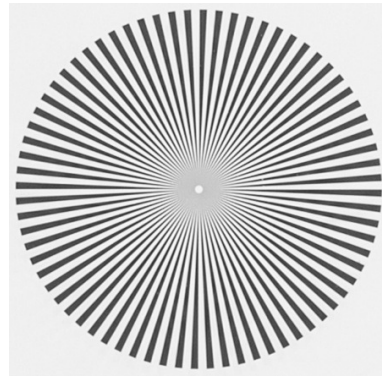

3.2 High-pass optical filtering

We consider the Abbe-Porter experiment of the problem 3.1, composed of two identical converging thin lenses of focal F . A square aperture of side d is placed in the object plane. It is illuminated under normal incidence by a monochromatic plane wave of wavelength λ and amplitude A . In the filtering plane, we place a mask of transmission $P(x, y) = b x$, proportional to x (with $b > 0$).

1. The mask in the filtering plane has a negative transmission for $x < 0$. Which optical components must we use to obtain this negative transmission?
2. The filtering made with this experiment is it a high-pass, low-pass, band-pass filtering ? Or something else (explain)?
3. Calculate the complex amplitude in the filtering plane, just after the mask $P(x, y)$, and plot the corresponding intensity as a function of x (take $y=0$ for the plot)
4. Calculate the complex amplitude in the image plane (you may drop the multiplicative constants in factor). Describe the image (in the xy plane), and plot the corresponding intensity as a function of x (take $y=0$ for the plot).
5. How is modified the amplitude in the image plane if the mask $P(x, y)$ is spatially limited by a slit of width ℓ in the x direction ? Plot the corresponding intensity as a function of x (take $y=0$ for the plot).

3.3 Image replication

We consider the Abbe-Porter experiment of problem 3.1, but we change the second lens L_2 so that its focal is F_2 . The distance between the filtering plane and L_2 is now F_2 , as well as the distance between L_2 and the image plane.

The object is a regular pentagon of width a and transmission $p(x, y)$ (transmission is 1 inside the pentagon, 0 outside). It is represented in the scheme below. It is not necessary to write explicitly the expression of $p(x, y)$.

In the filtering plane, we place a 2D grid whose transmission $P(x, y)$ is represented by a 2D Dirac comb of period b in both directions x and y .

1. Write down the object-image relation between amplitudes in the object and image planes (cf chapter 3). What is the difference with the case $F_2 = F$ (you may set $G = \frac{F_2}{F}$)?
2. Write down the transmission $P(x, y)$ of the grid
3. Calculate the point-spread function (PSF) of the optical filtering
4. Calculate the complex amplitude in the image plane, and make a sketch. Why do we talk about “image replication” for this problem ?
5. How must be chosen the period b of the grid to avoid overlap between successive images in the image plane ?

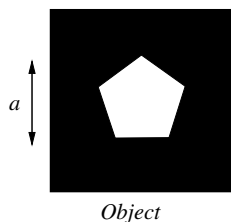

3.4 Optical filtering with coherent and incoherent light

We consider the following double-diffraction experiment composed of two lenses of focal F . An object is placed in the plane (A). Its transmission coefficient (in amplitude) is $t(x, y)$. It is filtered in the plane (B) by a circular pupil of diameter d . The resulting image is observed in the plane (C). We shall consider the two following cases:

- coherent light: incident plane wave of constant amplitude ψ_0 , normal incidence
- incoherent light: constant intensity of the incident light (normal incidence)

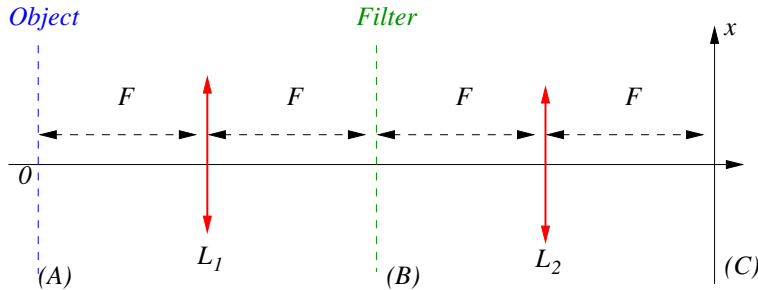

Coherent light

1. Calculate the complex amplitude $f(x, y)$ in the plane (C)
2. Write down the amplitude PSF $h(x, y)$ and the amplitude transfer function $\hat{h}(u, v)$.
3. Express the cutoff frequency f_c of this low-pass filter.
4. The object is made of two pinholes located at positions $(\pm \frac{x_0}{2}, 0)$ in the plane (A). Write down the intensity $I(x, y)$ in the plane (C) and plot it as a function of x (N.A.: $\lambda = 500$ nm, $F = 10$ cm, $d = 1$ cm, $x_0 = 1.5\lambda F/d$).
5. The object is a sinusoidal grid of spatial frequency m and contrast 1. What is the condition on m to observe a uniform image? N.A. : $\lambda = 500$ nm, $F = 10$ cm, $d = 1$ cm.
6. The object is a sinusoidal grid of frequency m and contrast 1, with m a function of the coordinate x (linear dependence $m = m_0 + bx$). Show that the image is uniform for certain values of x and make a qualitative plot of the intensity $I(x, y)$ in the image. N.A. : $m_0 = 20\text{mm}^{-1}$, $b = 20\text{mm}^{-2}$.



Incoherent light

The object has a transmission coefficient (in intensity) $t(x, y)$, so that the intensity in the plane (A) is $I_0(x, y) = C^{te} t(x, y)$. In incoherent light, it can be shown that there is a convolution relation between the intensity of the object $I_0(x, y)$ and the image $I(x, y)$, i.e. $I(x, y) = I_0(-x, -y) * S(x, y)$ with $S(x, y)$ the intensity PSF.

7. From results of section 1, derive the intensity PSF $S(x, y)$
8. Calculate the intensity transfer function $T(u, v)$ (you may normalize the transfer function so that $T(0, 0) = 1$).
9. Express the cutoff frequency f_c of this low-pass filter. What is the difference with the coherent case?
10. The object is made of two pinholes located at positions $(\pm \frac{x_0}{2}, 0)$ in the plane (A). Write down the intensity $I(x, y)$ in the plane (C) and plot it as a function of x (N.A.: $\lambda = 500$ nm, $F = 10$ cm, $d = 1$ cm $x_0 = 1.5\lambda F/d$). Is the object best resolved in coherent or incoherent light?
11. The object is a sinusoidal grid of spatial frequency m , its transmission coefficient (in intensity) is $t(x, y) = \frac{1}{2} + \frac{1}{2} \cos(2\pi mx)$. Calculate the intensity of the image and derive its contrast. What is the condition on m to observe a uniform image? N.A. : $\lambda = 500$ nm, $F = 10$ cm, $d = 1$ cm.
12. The object is a sinusoidal grid of frequency m and contrast 1, with m a function of the coordinate x (linear dependence $m = m_0 + bx$). Show that the contrast of the image depends of x (give its expression) and make a qualitative plot of the intensity $I(x, y)$ in the image. N.A. : $m_0 = 20\text{mm}^{-1}$, $b = 20\text{mm}^{-2}$.

3.5 Optical filtering by a pair of holes

We consider the Abbe-Porter experiment of exercise 3.4, composed of two identical converging thin lenses of focal F . The object has a amplitude transmission $t(x, y)$. It is illuminated under normal incidence by a monochromatic plane wave of wavelength λ and amplitude A . In the filtering plane, we place a mask of transmission $P(x, y)$.

1. Write down the complex amplitudes in the filtering plane and in the image plane.
2. Give the amplitude PSF $h(x, y)$ and the corresponding transfer function $\hat{h}(u, v)$

In the following, we suppose that the object transmission is $t(x, y) = \cos(2\pi mx)$ with $m > 0$. The filter $P(x, y)$ is composed of two circular apertures of diameter d . They are centered at positions $(x = \pm d, y = 0)$ in the filtering plane.

3. Plot the transfer function $\hat{h}(u, v)$ for $v = 0$ (put all relevant informations on your graphs (labels, particular values, etc...))
4. For which values of m do we have a non-zero intensity in the image plane? What kind of filtering is it?
5. For the values of m transmitted by the filter (corresponding to the previous question), calculate the intensity $I(x, y)$ in the image plane
6. We now use a variable frequency grid (the same as in exercise 3.4). Its spatial frequency depends on the x coordinate (linear variation $m(x) = m_0 + Kx$). The total length of the grid is $L = 1\text{cm}$. The spatial frequency varies from $m_0 = 50 \text{ mm}^{-1}$ at $x = 0$ to $m_1 = 550 \text{ mm}^{-1}$ at $x = L$. For which values of x do we have a uniform intensity in the image (N.A. $d = 1 \text{ cm}$, $F = 100 \text{ mm}$, $\lambda = 500 \text{ nm}$) ? Make a plot of $I(x, 0)$ (place all relevant informations on your graph).

The object transmission is again $t(x, y) = \cos(2\pi mx)$. One introduces a π phase shift on one of the two apertures of the filter $P(x, y)$.

7. Calculate and plot the new transfer function $\hat{h}(u, v)$ for $v = 0$. What are the new cutoff frequencies (compare with the situation without the π phase shift)?
8. For the frequencies m transmitted by the system, calculate the intensity $I_1(x, y)$ in the image plane. What are the differences with the question 5 (you may plot the two functions on the same graph for comparison).

3.6 Coherent optical filtering

We consider the following double-diffraction experiment composed of two lenses of focal F . A coherent object is placed in the plane (A). It is filtered in the plane (B) by a square pupil of side d with a parallel plate introducing a π phase shift on its leftern half (see figure on the right). The pupil transmission is $P(x, y) = -1$ for $-\frac{d}{2} < x < 0$; $|y| < d/2$ and $P(x, y) = 1$ for $0 < x < \frac{d}{2}$; $|y| < d/2$ (and of course $P(x, y) = 0$ if $|x| > d/2$ or $|y| > d/2$). Observations are made in monochromatic light at the wavelength λ , paraxial approximation is assumed for the whole problem.

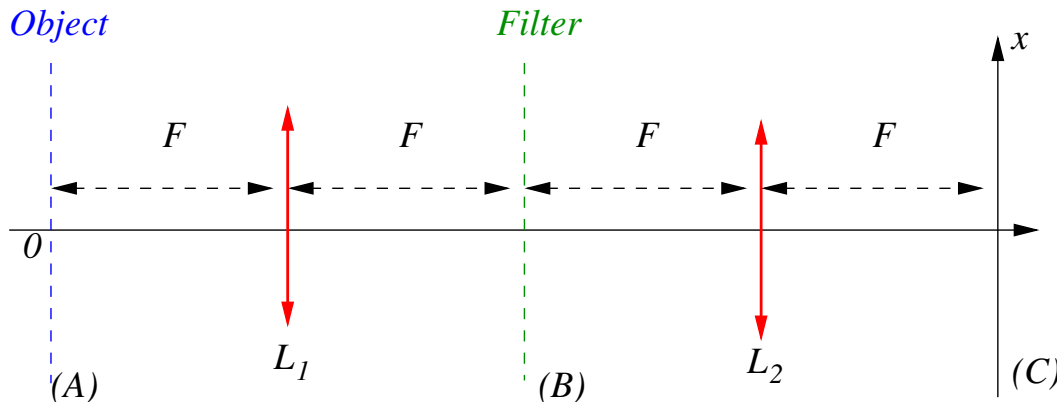
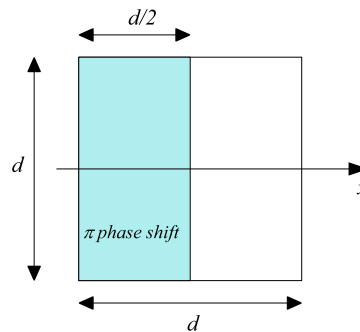

- Write down the pupil transmission $P(x, y)$ making use of the rectangular function Π .
- The object is a on-axis point-source in the plane (A).
 - Write the complex amplitude $f_0(x, y)$ in the plane (A)
 - Calculate the complex amplitude $f_1(x, y)$ in the plane (B), at the output of the pupil.
 - Calculate the complex amplitude $f_2(x, y)$ in the place (C) and the corresponding intensity $I_2(x, y)$
 - Plot $I_2(x, 0)$ (put all relevant informations on your graph). What in the on-axis intensity value?
- The object in the plane (A) is now a periodic grid, and the corresponding amplitude is $f_0(x, y) = \psi_0 \cos\left(\frac{2\pi x}{a}\right)$
 - Calculate the complex amplitude $f_1(x, y)$ in the plane (B), just before the pupil $P(x, y)$.
 - What is the condition on a to observe a non-uniform image in the plane (C)?
 - Assuming that the previous condition is fulfilled, calculate the intensity in the image plane and make a plot.
 - What are the differences with the case where there is no parallel plate on the pupil $P(x, y)$?

3.7 Phase contrast

The optical setup below is composed of two identical conjugated lenses of focal length $F = 1$ m (Abbe-Porter double diffraction setup). The incident plane wave as a complex amplitude Ae^{ikz} (normal incidence).

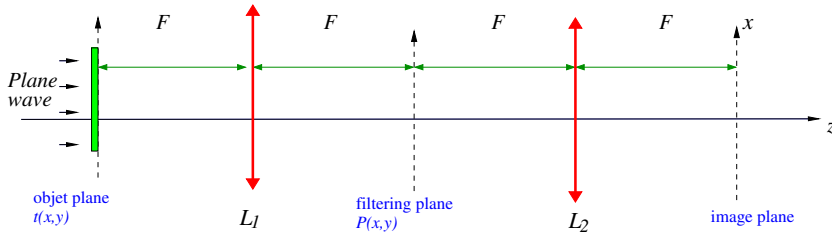

The object has a complex transmission $t(x, y)$. It is a square parallel plate of side $a \ll D$, refractive index n and thickness e . The center of this object is on the z axis. The object is lit by a plane wave of amplitude A . For questions 1 to 6, nothing is placed in the filtering plane.

- Without calculation, describe the image (intensity) in the image plane.
- Give the phase shift φ produced by the plate (N.A. : $n = 1.00001$, $e = 0.1$ mm, $\lambda = 600$ nm, $\pi \simeq 3$).
- Assuming $|\varphi| \ll 1$, write down the transmission coefficient $t(x, y)$ of the object (*remember that the plate has a side a and has no effect on the light outside the square of side a*),
- Calculate the complex amplitude $f_1(x, y)$ in the filtering plane
- Give the width of the diffracted amplitude in the filtering plane. N.A.: $a = 10 \mu\text{m}$.
- Make a plot of $f_1(x, 0)$ (drop the constant terms in factor). Use different colors for the real and imaginary parts. Put all relevant informations on the plot (amplitudes, size, labels...)

In the filtering plane is placed a circular parallel plate of very small diameter. This plate is partly absorbent, its transmission is $t_2 = \tau e^{i\pi/2}$ with τ real. We suppose that d is small enough so that the circular plate shadows the bright central peak, with almost no effect on the light diffracted by the square plate

- Give the complex amplitude in the filtering plane, just after the circular plate.
- Calculate the intensity $I_2(x, y)$ in the image (remind that $|\varphi| \ll 1$, neglect terms in φ^2).
- Make a plot of $I_2(x, 0)$. Put all relevant informations on the plot. Describe the image in the image plane, compare with question 1.
- Calculate the contrast C of the image. What is the relation between φ and τ to have $C = 10\%$?

4 Exercises for chapter 4

4.1 Image of a double star and pupil apodization

A telescope has a circular pupil $P(x, y)$ of diameter d . With this telescope, one observes a star with a companion. We denote as r the intensity ratio of the companion and the main star, and ϕ the angular separation of the couple. The angular intensity distribution of the source is $I_0(\alpha, \beta) = A[\delta(\alpha, \beta) + r\delta(\alpha - \phi, \beta)]$. For numerical applications, we shall consider the following values : $d = 1\text{m}$, $\lambda = 500\text{nm}$.

1. Write the angular intensity PSF $S(\alpha, \beta)$ at the focal plane of the telescope.
2. What is the angular resolution (Rayleigh definition) θ_0 of the telescope ? Calculate its numerical value in arcsec
3. Write the intensity $I(\alpha, \beta)$ of the image of the couple, express it as the sum of two terms $I_1(\alpha, \beta)$ and $I_2(\alpha, \beta)$ (I_1 is produced by the star, I_2 by the companion)
4. Using your computer, plot (on the same graph) the intensities $I_1(\alpha, 0)$, $I_2(\alpha, 0)$ and $I(\alpha, 0)$ as a function of α for $r = 1$ and $\phi = 0.2$ arcsec (for the horizontal axis, you may display values in arcsec).
5. Make a gray-level plot of the 2D intensity $I(\alpha, \beta)$ (use the python function `pcolor`).
6. Do the same for $\phi = \theta_0$ (Rayleigh limit): is the couple resolved ? Same question for $\phi = \frac{\lambda}{d}$. Which value seems more suitable to define a limit of resolution: θ_0 or $\frac{\lambda}{d}$?
7. We take $r = 0.001$ and $\phi = 0.3$ arcsec. Plot the intensities $I_1(\alpha, 0)$, $I_2(\alpha, 0)$ and $I(\alpha, 0)$ as a function of α (use a log scale for the y axis).
8. Still with $r = 0.001$ and $\phi = 0.3$ arcsec, calculate $I_2(-\phi, 0)$ and $I_1(-\phi, 0)$ and show that the companion is fainter than the light coming from the main star.

The telescope pupil is now apodized, so that it is multiplied by a Gaussian transmission $G(x, y) = \exp\left(-\frac{\rho^2}{w^2}\right)$, with $\rho^2 = x^2 + y^2$ and $w = \frac{d}{4}$ the width of the Gaussian. The new pupil function is then $P_2(x, y) = P(x, y).G(x, y)$. We shall neglect the effects of the pupil edges (so that $P_2(x, y) \simeq G(x, y)$).

9. Plot the pupil function $P_2(x, 0)$ as a function of x (do not forget the circular disc). What do you think of the hypothesis "we shall neglect the effects of the pupil edges" (Hint: compare your graph with the case $w = d/2$)
10. One defines the angular resolution Δ of this telescope as the FWHM of its PSF (because there is no Rayleigh limit for a Gaussian pupil). Calculate the PSF and express Δ as a function of $\frac{\lambda}{d}$. Compare with the resolution of the unapodized pupil.
11. Repeat question 4 for this pupil with $r = 1$ and $\phi = \Delta$. Is the couple resolved ?
12. Repeat question 7 for this pupil. Is the companion detectable ? Calculate $I_2(-\phi, 0)$ and $I_1(-\phi, 0)$ and show that the companion is now brighter than the light diffracted by the main star.
13. What would become the PSF if one does not neglect the effects of the pupil edges ? Express it as a convolution (you might calculate it numerically with your computer).

4.2 Measurement of the angular diameter of a star

In 1920, making use of the 2.5m telescope of Mt Wilson, Michelson and Pease made the first measurement of the angular diameter of a star (Michelson A., Pease F., 1921, ApJ **53**, 249). They published a value of 0.047 arcsec for the star Betelgeuse. They used a 2-holes mask at the entrance pupil of the telescope. The masks were small and in this problem we shall consider them as pinholes (transmission described by a Dirac δ distribution). The separation between the holes is denoted as d . The source star is described by a circular uniform disc of angular diameter θ_0 . Observations are made at the wavelength λ .

1. Write down the angular PSF $S(\alpha, \beta)$ of this pupil
2. Express the angular intensity distribution $I(\alpha, \beta)$ in the focal plane as a convolution.
3. Show that the image exhibit fringes (hint : calculate the Fourier transform of $I(\alpha, \beta)$)
4. Show that the fringe contrast (i.e. *visibility*) vanish for several values of d . Propose a method to derive the angular diameter of the star.
5. The former interferometer I2T, operating on the plateau de Calern in the years 1980, was composed of two small telescopes which could be moved on rails up to a separation of 140 m. What is the smallest angular diameter measurable by I2T at $\lambda = 500$ nm ?

4.3 Image of a sinusoidal grid

A telescope with circular pupil of diameter d observes an extended source described by the angular intensity distribution $I_0(\alpha, \beta) = A \cos^2\left(\frac{\pi\alpha}{a}\right)$ with a a positive number. Observations are made at the wavelength λ .

1. Calculate the angular intensity distribution $I(\alpha, \beta)$ at the focal plane (hint: do the calculation in the Fourier plane. You may drop multiplicative constants in factor).
2. On the same graph, plot the intensities $I_0(\alpha, 0)$ and $I(\alpha, 0)$ as a function of α .
3. The angular period of the source is 50 mas (milli arcsec). What is the minimum telescope diameter d_1 to observe a non-uniform image at $\lambda = 600 \text{ nm}$?
4. The telescope diameter being fixed to d_1 , what is the value of the contrast of the image at $\lambda = 400 \text{ nm}$?

The telescope pupil is now a square of side d (sides are parallel to directions α and β).

5. Calculate the transfer function for this aperture. What is the cutoff frequency in the direction α ? Compare with the circular pupil: is the resolution better with the circular or the square pupil?
6. Same questions as 3 and 4 for the square pupil. Which image has a better contrast at $\lambda = 400 \text{ nm}$ if $d = d_1$?

4.4 Diluted pupil with two circular apertures

The pupil of an interferometer is composed of two circular apertures of diameter d , distant of a separation $B > d$ in the x direction (scheme on the right). Observations are made in monochromatic light at the wavelength λ .

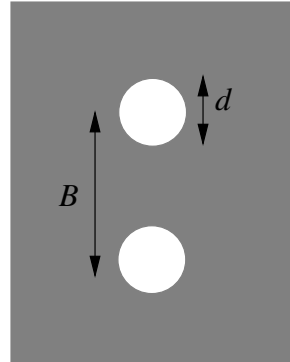

1. Calculate the angular intensity PSF $S(\alpha, \beta)$ and plot $S(\alpha, 0)$ as a function of α for $B = 4d$ and $\lambda = 600 \text{ nm}$.
2. Use your computer to make a gray-level plot of $S(\alpha, \beta)$
3. How many fringes are visible in the central peak of the Airy disc ? N.A.: $B = 2d$ (this value almost corresponds to the pupil of the Large Binocular Telescope (Arizona), $B = 1.7d$)
4. The source is a double star of angular separation Δ in the α direction. Stars have the same magnitude. Write the angular intensity distribution $I(\alpha, \beta)$ at the focal plane, and make a gray-level plot of $I(\alpha, \beta)$ for $\Delta = 4\frac{\lambda}{d}$ and $B = 2d$.
5. Calculate the transfer function $T(u, v)$ and give angular cutoff frequencies u_c and v_c in directions u and v
6. Show that the angular resolution of this interferometer (defined as the cutoff period) is equal, in the u direction, to that of a large circular aperture (give its diameter).
7. In the case $B < 2d$, explain why the transfer function does not vanish in the interval $u \in [-u_c, u_c]$ for $v = 0$.

4.5 Study of a defocus aberration

We consider a telescope with square pupil of side d (the pupil is taken square and not circular for a sake of simplicity). Images of incoherent objects are observed at the focal plane of the telescope (focal length F), the light is monochromatic (wavelength λ). The lens of the telescope is not perfect: there is a phase aberration $W(x, y)$ so that the pupil of the telescope is multiplied by the complex term $\exp[iW(x, y)]$ (this product is called *generalized pupil function*). The function $W(x, y)$ is given by

$$W(x, y) = \frac{\pi}{\lambda} \epsilon (x^2 + y^2)$$

with $\epsilon \ll \frac{1}{F}$.

1. Show that the aberration changes the focal length of the telescope, so that it becomes F' (hint: express the transmission coefficient of the telescope lens in presence of the phase aberration). Express F' as a function of F . If $\epsilon > 0$, does this correspond to intrafocal or extrafocal images ?
2. What is the optical path difference w produced by the aberration term between the center of the pupil and its edge (consider the point $(\frac{d}{2}, 0)$) ?
3. Calculate the angular intensity PSF $S(\alpha, \beta)$ of this generalized pupil $P(x, y)$. Express it with a convolution product (do not calculate the convolution analytically, but you may try to do it numerically using python fft2 function).
4. Show that the angular transfer function $T(u, v)$ of the generalized pupil $P(x, y)$ is a separable function in u and v , and that it must be real and even ($T(-u, -v) = T(u, v)$). Calculate $T(u, v)$. We recall that

$$T(u, v) = \frac{1}{S} \iint_{-\infty}^{\infty} P(x, y) \overline{P(x + \lambda u, y + \lambda v)} dx dy$$

with S the pupil surface.

5. What are the cutoff frequencies u_c and v_c in the u and v directions ?
6. Examine the limit of $T(u, v)$ when $\epsilon \rightarrow 0$. In this case the aberration term vanishes, and you should obtain the transfer function of an un-aberrated rectangular pupil.
7. With your computer, plot the transfer function $T(u, 0)$ for $0 < u < 1.2u_c$ in the cases $w = \frac{\lambda}{4}$, $w = \frac{\lambda}{2}$, and $w = 0.6\lambda$. Numerical values are $\lambda = 500\text{nm}$, $d = 1\text{m}$.
8. The object observed by the telescope is a sinusoidal grid of spatial period a in the x direction, located at a distance D from the pupil (with $D \gg F$). The defocus aberration corresponds to $w = 0.6\lambda$. Using your graph above, show that the contrast of the image vanishes for several values of a , and give the two largest values a_1 and a_2 . (N.A. : $D = 10\text{km}$, $\lambda = 500\text{nm}$, $d = 1\text{m}$). If $a_1 < a < a_2$, show that there is a *contrast reversal*, i.e. a swap between dark and bright fringes.

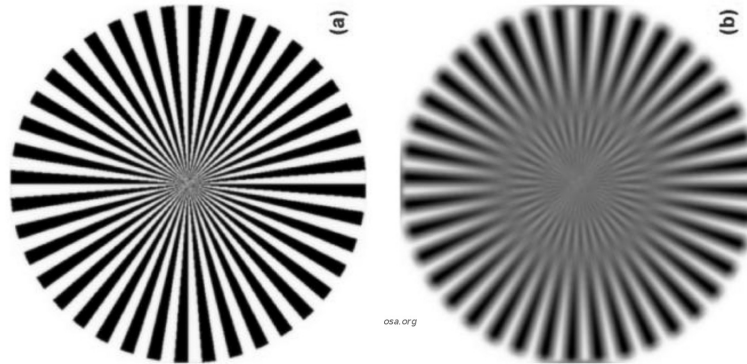

Images of a Siemens star: (a) perfect image. (b) defocused image showing contrast reversal.

4.6 Rectangular pupil with phase shift

We consider a telescope with a rectangular pupil of width b in the x direction and $2a$ in the y direction. A parallel plate introducing a π phase shift is placed over the upper half of this pupil (see scheme). Observations are made in the focal plane of the telescope at the wavelength λ , in incoherent light.

1. Calculate the angular intensity PSF $S(\alpha, \beta)$ as a function of angles α and β . Plot the PSF and compare it to the case where there is no parallel plate
2. Calculate the optical transfer function $T(u, v)$ by two different ways.
3. Plot $T(u, 0)$ and compare it to the case where there is no parallel plate.

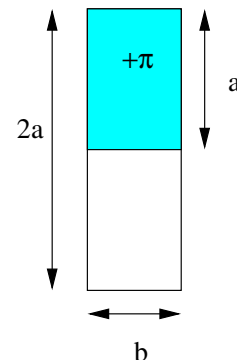

4.7 A simple pistonscope

We consider a telescope with a pupil made of 2 circular apertures of diameter d , distant from $a > 2d$. The baseline (line joining the two apertures) is parallel to the x direction. The light is monochromatic (wavelength λ). The wavefront is not flat, and there is a phase shift ϕ between the two apertures (i.e. the complex amplitude on the aperture centered at $x = \frac{a}{2}$ is multiplied by $e^{i\phi}$). This phase shift corresponds to an optical path difference (OPD) δ as shown on the sketch.

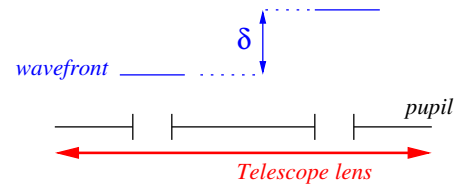

1. Write down the relation between ϕ and δ .
2. Write down the *generalized pupil function* $P(x, y)$ including the phase shift (the point $(x, y) = (0, 0)$ will be taken between the two apertures).
3. Calculate the intensity PSF $S(\alpha, \beta)$ as a function angles (α, β) . Make a plot of $S(\alpha, 0)$ (write relevant informations on the axes, labels,...)
4. How many fringes are present in the central peak of the PSF ?
5. Show that the fringes are shifted by a quantity Δ , and express Δ as a function of the OPD δ
6. The PSF is recorded by a camera whose pixel size is p ($p = 10\mu\text{m}$). The focal length is F . What is the value of δ corresponding to a fringe displacement of 1 pixel on the camera? N.A. : $a = 1\text{m}$, $F = 10\text{m}$.
7. Calculate the normalized optical transfer function $T(u, v)$ for this generalized pupil. What are the differences with the case $\phi = 0$?
8. Make a plot of $|T(u, 0)|$ (write relevant informations on the axes, labels,...).
9. What is the angular resolution of this telescope? What is the difference with the case $\phi = 0$?
10. The object observed by the telescope is a sinusoidal grid of spatial period ℓ (ℓ is a length) in the x direction, located at a distance D from the pupil (with $D \gg F$). Give the conditions on ℓ to observe a non-uniform image. N.A.: $D = 1\text{km}$, $\lambda = 500\text{nm}$, $d = 10\text{cm}$, $a = 1\text{m}$.

4.8 Circular disc with limb darkening

We consider an interferometer with a pupil made of two holes separated by a distance B (*baseline*) along the x direction. The diameter of the two holes is supposed to be infinitely small. The astronomical (incoherent) source observed by the instrument has an intensity distribution $I_0(\alpha, \beta)$ as function of angles α and β (α is taken parallel to the x direction). The function $I_0(\alpha, \beta)$ is supposed even. The source is monochromatic, the wavelength is λ .

1. Write down the pupil function $P(x, y)$ of the interferometer
2. Calculate the angular PSF $S(\alpha, \beta)$
3. Calculate the corresponding transfer function. Which angular frequencies are accessible to this interferometer?
4. Calculate the intensity $I(\alpha, \beta)$ in the image and show that it is composed of fringes (we recall that $I_0(\alpha, \beta)$ is an even function).
5. Express the fringe contrast as a function of the baseline B (visibility function).

Two different objects are observed by this interferometer:

Object 1: a uniform disc of angular diameter θ_0 . The corresponding angular intensity distribution is denoted as $I_1(\alpha, \beta)$

Object 2: a disc with smooth edges (example of a star with limb darkening) The angular intensity distribution is modelled by the convolution $I_2(\alpha, \beta) = I_1(\alpha, \beta) * g(\alpha, \beta)$ with $g(\alpha, \beta) = \exp\left[-\left(\frac{\sqrt{\alpha^2 + \beta^2}}{L}\right)^2\right]$ a gaussian function of with $L \ll \theta_0$. The two functions $I_1(\alpha, 0)$ and $I_2(\alpha, 0)$ are shown hereafter.

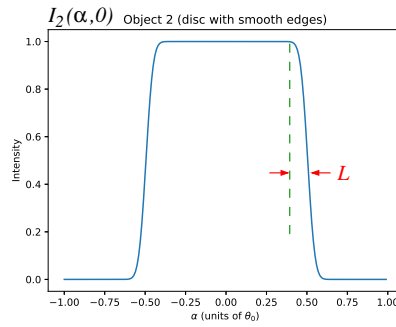
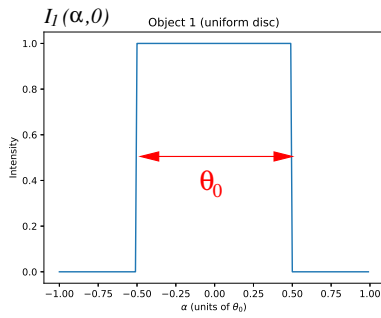

We want to measure L by comparing visibility curves obtained with both objects.

6. Write the visibility function $V_1(B)$ for the object 1.
7. Explain how you would measure the angular diameter θ_0 from the visibility $V_1(B)$.
8. Give the baseline B_m corresponding to the first secondary maximum of V_1 . What is the numerical value of the fringe contrast $V_1(B_m)$?
9. Write the visibility function $V_2(B)$ for the object 2, and give its value at $B = B_m$.
10. Propose a method to estimate L from the two visibilities V_1 and V_2 .

4.9 Circumstellar ring

We consider an interferometer with a pupil made of two holes separated by a distance B (baseline) along the x direction. The diameter of the two holes is supposed to be infinitely small. The astronomical (incoherent) source observed by the instrument is a circumstellar ring of angular radius φ ($\varphi \ll 1$).

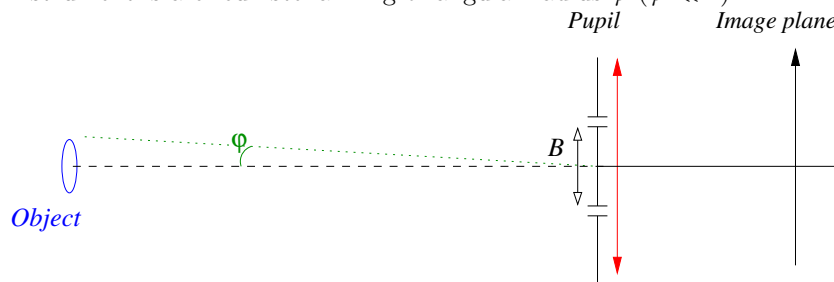

The intensity distribution of the object, function of the angles α and β (α is taken parallel to the x direction), is modelled as $I_0(\alpha, \beta) = A\delta(\theta - \varphi)$ with A a constant and $\theta = \sqrt{\alpha^2 + \beta^2}$. The source is monochromatic, the wavelength is λ .

1. Express the pupil function $P(x, y)$ of the interferometer
2. Calculate the angular PSF $S(\alpha, \beta)$ (you may drop multiplicative constants in factor) and make a plot of $S(\alpha, 0)$ as a function of α (put everything that you think useful on your graph).
3. Calculate the transfer function $T(u, v)$. Which angular frequencies are accessible to this interferometer?
4. Calculate the intensity $I(\alpha, \beta)$ in the image (hint: make use of the transfer function).
5. Show that the image is composed of fringes and give the fringe period.
6. Calculate the fringe contrast $C(B)$.
7. Using the graphs below, give an approximation of the first zero of the contrast (i.e. the smallest value B_1 for which $C(B_1) = 0$).
8. What is the phenomenon of “contrast reversal”? Does it happen here (and in that case, for which values of B)?
9. Make a plot of the intensity $I(\alpha, 0)$ for $B = B_1/2$. What are the differences with the graph of $S(\alpha, 0)$ (question 2)?
10. The first zero of the contrast is obtained for $B_1 = 1\text{m}$. What is the angular radius φ of the circumstellar ring in arcseconds (the wavelength is $\lambda = 1\mu\text{m}$)?

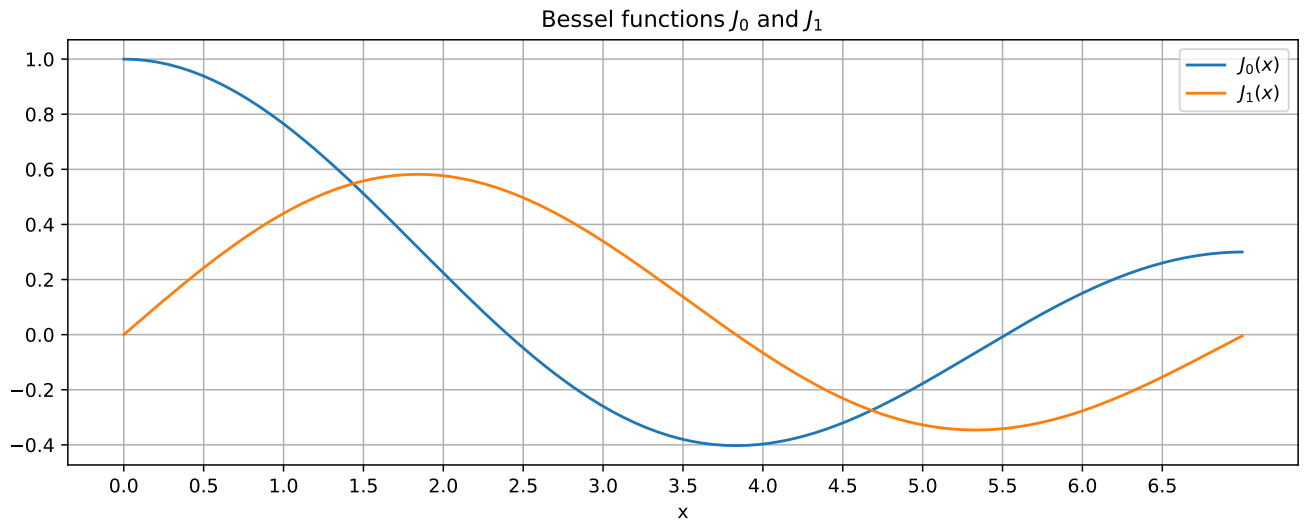

4.10 3 apertures interferometer

An interferometer has a pupil made of 3 pin-holes (considered as Dirac δ functions) located at positions $(0, 0)$ and $(\pm B, 0)$ in the pupil plane (see scheme below). On the central one is placed a parallel plate giving a phase shift ϕ to the incident light. The light is monochromatic, of wavelength λ .

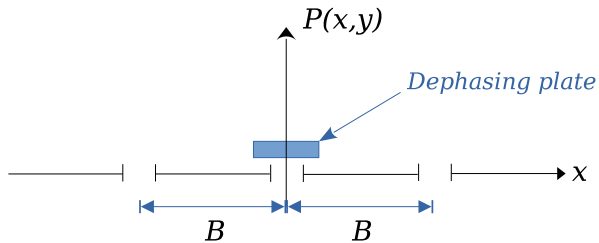

1. Write down the generalized pupil function $P(x, y)$ including the phase shift.
2. Calculate the intensity PSF $S(\alpha, \beta)$ as a function of angles α and β .
3. Calculate the corresponding transfer function $T(u, v)$.
4. Make a plot of $T(u, 0)$ in the case $\phi = 0$. Put all relevant informations on the plot (amplitudes, particular values, labels...). Which angular frequencies are seen by this interferometer?
5. Same question for $\phi = \pi/2$. Comments?
6. We assume that $\phi = \pi/2$. The object observed is a circular disc of intensity A and angular diameter θ_0
 - (a) Write down the intensity distribution $I_0(\alpha, \beta)$ of the object
 - (b) Making use of the transfer function, calculate the intensity $I(\alpha, \beta)$ in the image plane.
 - (c) Calculate the contrast C of the fringes in the image plane, and plot C as a function of B .
 - (d) What is the lowest value of B for which the contrast is 0?

Appendix: Solutions to exercises

Exercises for chapter 0

1-dim Fourier transforms

1. If $f(x) = a + b \cos(2\pi u_0 x)$ then $\hat{f}(u) = a\delta(u) + \frac{b}{2}\delta(u - u_0) + \frac{b}{2}\delta(u + u_0)$ (both functions are real and even). If $f(x) = a + b \sin(2\pi u_0 x)$ then $\hat{f}(u) = a\delta(u) - \frac{ib}{2}\delta(u - u_0) + \frac{ib}{2}\delta(u + u_0)$ (the sine is responsible for the imaginary part of the Fourier transform).
2. $\hat{f}(u) = \frac{a}{2} \text{sinc}(\pi a(u + u_0)) + \frac{a}{2} \text{sinc}(\pi a(u - u_0))$
3. f expresses as the convolution: $f(x) = \Pi\left(\frac{x}{b}\right) * [\delta(x + \frac{a}{2}) + \delta(x - \frac{a}{2})]$. Its Fourier transform is $\hat{f}(u) = 2b \text{sinc}(\pi u b) \cdot \cos(\pi u a)$.
4. $\hat{f}(u) = a \text{sinc}(\pi u a) \text{III}(2au)$ (the Dirac comb has a period $\frac{1}{2a}$). If f is multiplied by a rectangular function $\Pi(\frac{x}{L})$ then $\hat{f}(u)$ is convolved by $L \text{sinc}(\pi u L)$. Expanding the Dirac comb leads to

$$\hat{f}(u) = \frac{L}{2} \sum_{n=-\infty}^{\infty} \text{sinc}\left(\frac{\pi n}{2}\right) \text{sinc}\left(\pi L\left(u - \frac{n}{2a}\right)\right)$$

5. The Fourier transform of $g_a(x)$ is $\hat{g}_a(u) = \exp(-\pi(ua\sqrt{2\pi})^2)$. The Fourier transform of the convolution $g_a * g_b$ is $\exp[-\pi(u\sqrt{a^2 + b^2}\sqrt{2\pi})^2]$. By identification, we recognize the Fourier transform of $g_{\sqrt{a^2 + b^2}}$

2-dim Fourier transforms

1. $f(x, y) = \Pi(\frac{x}{a}) \cdot \Pi(\frac{y}{b})$ is a separable function, so its Fourier transform is also separable: $\hat{f}(u, v) = ab \text{sinc}(\pi u a) \cdot \text{sinc}(\pi v b)$.
2. f can be written as $f(x, y) = \Pi(\frac{\rho}{d}) \cdot \cos^2(\frac{\pi x}{a})$ with $\rho = \sqrt{x^2 + y^2}$. So $\hat{f}(u, v) = S \text{jinc}(\pi d q) + \frac{S}{2} \text{jinc}\left(\pi d \sqrt{(u + \frac{1}{a})^2 + v^2}\right) + \frac{S}{2} \text{jinc}\left(\pi d \sqrt{(u - \frac{1}{a})^2 + v^2}\right)$ with $S = \frac{\pi d^2}{4}$ and $q = \sqrt{u^2 + v^2}$
3. The function is $f(x, y) = \Pi(\frac{\rho}{d}) * [\text{III}_a(x) \cdot \mathbf{1}(y)]$. Its Fourier transform is $\hat{f}(u, v) = 2S \text{jinc}(\pi d q) \cdot \text{III}(au)$ (a “striped” jinc function with period $\frac{1}{a}$).
4. Hints: the 2D Fourier transform of f is $\iint_{-\infty}^{\infty} f(x, y) \exp(2i\pi(ux + vy)) dx dy$. Make the variable change $x = \rho \cos \theta$, $y = \rho \sin \theta$, $u = q \cos \phi$, $v = q \sin \phi$ (polar coordinates in direct and Fourier domains). The term $(ux + vy)$ becomes $q\rho \cos(\theta - \phi)$. The Bessel function $J_0(X)$ can also be written as $J_0(X) = \frac{1}{2\pi} \int_0^{2\pi} \exp(iX \cos(\theta - \phi)) d\theta \forall \phi$ because $\exp(iX \cos \theta)$ is 2π periodic in θ .
5. $\hat{f}(u, v) = \frac{\pi d^2}{2} \text{jinc}(\pi d q)$

Exercises for chapter 1

Ex. 1.1: Fresnel diffraction of elementary waves

1. Fresnel PSF: $D_z(x, y) = \frac{1}{i\lambda z} e^{\frac{i\pi \rho^2}{\lambda z}}$ with $\rho^2 = x^2 + y^2$. The transfer function is $D_z(u, v) = e^{-i\pi \lambda z q^2}$ with $q^2 = u^2 + v^2$.

2. A plane wave under normal incidence has an amplitude $\psi_0 e^{ikz}$ in any plane z . This is the result we expect to retrieve using Fresnel diffraction between planes $z = 0$ and $z > 0$, i.e. applying the relation $f_z(x, y) = e^{ikz} (f_0 * D_z)(x, y)$. The steps are

- start with $f_0(x, y) = \psi_0$
- make a Fourier transform: $\hat{f}_0(u, v) = \psi_0 \delta(u, v)$
- make the product of \hat{f}_0 by \hat{D}_z in the Fourier plane. This gives $\hat{f}_z(u, v) = e^{ikz} \psi_0 \delta(u, v) \cdot \hat{D}_z(u, v) = e^{ikz} \psi_0 \delta(u, v)$
- make an inverse Fourier transform, we obtain the expected result $f_z(x, y) = \psi_0 e^{ikz}$

3. A diverging spherical wave with source at $(0, 0, -z_s)$ has a complex amplitude

$$f_z(x, y) = \frac{S_0}{z + z_s} e^{ik(z+z_s)} e^{\frac{i\pi\rho^2}{\lambda(z+z_s)}}$$

as for the previous question, we would like to retrieve this result using Fresnel diffraction. The steps are the same as above, i.e.

- start with $f_0(x, y) = \frac{S_0}{z_s} e^{ikz_s} e^{\frac{i\pi\rho^2}{\lambda z_s}}$
- calculate the Fourier transform: $\hat{f}_0(u, v) = \frac{S_0}{z_s} e^{ikz_s} e^{-i\pi\lambda z_s q^2}$
- multiply by \hat{D}_z and obtain

$$\hat{f}_z(u, v) = i\lambda S_0 e^{ik(z+z_s)} e^{-i\pi\lambda(z+z_s)q^2}$$

- make an inverse Fourier transform to get the expected result.

Ex. 1.2: Fresnel diffraction of a periodic pattern — Talbot effect

1. The calculation is simple in the Fourier plane, using the transfer function $\hat{D}_z(u, v)$. We obtain

$$f_z(x, y) = A e^{ikz} \left[1 + \epsilon e^{-i\pi\lambda z/a^2} \cos\left(\frac{2\pi x}{a}\right) \right]$$

2. If $\epsilon \ll 1$ we neglect the second order terms in ϵ^2 , this gives

$$I_z(x, y) \simeq |A|^2 \left(1 + 2\epsilon \cos\left(\frac{\pi\lambda z}{a^2}\right) \cos\left(\frac{2\pi x}{a}\right) \right)$$

3. In a Talbot plane, $I_z(x, y) = I_0(x, y)$. This happens for $z_p = \frac{2pa^2}{\lambda}$, p integer. The Talbot length is $z_T = \frac{2a^2}{\lambda}$

4. For $z = z_T/4$ and $3z_T/4$, the intensity is uniform (no fringes). For $z = z_T/2$, the intensity is $I_z(x, y) = |A|^2 \left(1 - 2\epsilon \cos\left(\frac{2\pi x}{a}\right) \right)$. There is a - sign in front of the cosine term, resulting in a half-period shift of the fringes compared to the plane $z = 0$ (contrast reversal).

Ex. 1.3: Fresnel diffraction by a circular aperture

1. $f_z(x, y) = e^{ikz} (f_0 * D_z)(x, y)$. For $x = y = 0$, the convolution integral takes the form

$$f_z(0, 0) = \psi_0 \frac{e^{ikz}}{i\lambda z} \iint_{-\infty}^{\infty} f_0(x', y') e^{\frac{i\pi\rho'^2}{\lambda z}} dx' dy'$$

with $\rho'^2 = x'^2 + y'^2$

2. Polar form of the integral;

$$f_z(0, 0) = \psi_0 \frac{2\pi e^{ikz}}{i\lambda z} \int_0^{d/2} \rho' e^{\frac{i\pi\rho'^2}{\lambda z}} d\rho'$$

3. Hint to calculate the integral: the derivative of e^{ax^2} is $2ax e^{ax^2}$. We obtain

$$f_z(0, 0) = \psi_0 e^{ikz} \left(1 - e^{\frac{i\pi d^2}{4\lambda z}} \right)$$

The intensity can be put in the form: $I_z(0, 0) = 2|\psi_0|^2 \left(1 - \cos\left(\frac{\pi d^2}{4\lambda z}\right) \right)$

4. Zero intensity for $z_p = \frac{d^2}{8p\lambda}$, p integer

Ex. 1.4: the Moon laser at the Plateau de Calern

1. The wave intensity $|A|^2$ is its power per unit surface, so $W = S|A|^2$ with $S = \frac{\pi d^2}{4}$
2. Amplitude at Moon surface $f_D(x, y) = \frac{Ae^{ikD}}{i\lambda D} 2S \text{jinc} \left(\frac{\pi d \rho}{\lambda D} \right)$. Diameter of the first dark Airy ring: $\mathcal{L}_1 = \frac{2.44\lambda D}{d} = 312\text{m}$
3. $\psi_0 = \frac{ASe^{ikD}}{i\lambda D}$. $I_0 = |\psi_0|^2 = \frac{WS}{\lambda^2 D^2}$
4. If $a \ll \mathcal{L}_1$ the mirror is almost uniformly lit with an amplitude $f_D(0, 0)$. Hence $W_1 = S_1 |f_D(0, 0)|^2 = \frac{WS S_1}{\lambda^2 D^2}$ with $S_1 = \frac{\pi a^2}{4}$ the mirror surface. Numerical value: $\frac{W_1}{W} = 3.4 \cdot 10^{-8}$
5. Same calculation as in question 2, replacing d by a and A by $f_D(0, 0)$. Diameter of the first dark ring: $\mathcal{L}_2 = \frac{2.44\lambda D}{a} = 15\text{km}$. Intensity at center: $I_1 = \frac{|A|^2 S^2 S_1^2}{\lambda^4 D^4}$.
6. $W_2 = S I_1$, so $\frac{W_2}{W} = \frac{WS^2 S_1^2}{\lambda^4 D^4} = 1.1 \cdot 10^{-15}$

Ex. 1.5: aperture synthesis

1. Screen transmission: $t(x, y) = \Pi(\frac{\rho}{d}) * [\delta(x - \frac{a}{2}) + \delta(x + \frac{a}{2})]$. Diffracted intensity: $I(\alpha, \beta) = \left(\frac{4|\psi_0|S}{\lambda z} \right)^2 \text{jinc} \left(\frac{\pi \theta d}{\lambda} \right)^2 \cos^2(\pi \frac{\alpha}{a} \lambda)$ with $S = \frac{\pi d^2}{4}$ and $\theta = \sqrt{\alpha^2 + \beta^2}$. Diameter of the first dark Airy ring: $\frac{2.44\lambda D}{d}$. Fringe period: λ/a (smaller than the Airy disc size, so the image looks like a striped Airy disc).
2. Intensity:

$$I(\alpha, \beta) = \left(\frac{2|\psi_0|S}{\lambda z} \right)^2 \text{jinc} \left(\frac{\pi \theta d}{\lambda} \right)^2 \left[3 + 2 \cos \left(\frac{2\pi}{\lambda} \vec{\theta} \cdot \vec{B}_{12} \right) + 2 \cos \left(\frac{2\pi}{\lambda} \vec{\theta} \cdot \vec{B}_{13} \right) + 2 \cos \left(\frac{2\pi}{\lambda} \vec{\theta} \cdot \vec{B}_{23} \right) \right]$$

with $\vec{\theta} = (\alpha, \beta)$ and $\vec{B}_{ij} = \vec{\rho}_j - \vec{\rho}_i$ the distance between the 3 hole pairs. The term between the brackets $[\]$ is an interference pattern made of 3 fringe systems (3 cosine terms) corresponding to the 3 hole pairs. The whole fringe pattern is multiplied by an Airy function jinc^2 corresponding to the diffraction by individual holes.

3. Intensity:

$$I(\alpha, \beta) = \left(\frac{2|\psi_0|S}{\lambda z} \right)^2 \text{jinc} \left(\frac{\pi \theta d}{\lambda} \right)^2 \left[10 + 2 \sum_{j=1}^{10} \sum_{i \neq j} \cos \left(\frac{2\pi}{\lambda} \vec{\theta} \cdot \vec{B}_{ij} \right) \right]$$

The interference function between the brackets $[\]$ is made of $\frac{N(N-1)}{2}$ cosine terms (with $N = 10$) corresponding to the $\frac{N(N-1)}{2}$ possible bases \vec{B}_{ij} . At its center, it exhibits a pseudo-Airy disc of size $\sim \frac{\lambda}{a}$, similar to to diffraction pattern of a circular diaphragm of diameter a .

Ex. 1.6: circular pupil with central obstruction

1. Diffracted amplitude:

$$f(\alpha, \beta) = \frac{Ae^{ikz}}{i\lambda z} \left[2S \text{jinc} \left(\frac{\pi d \theta}{\lambda} \right) - 2S_1 \text{jinc} \left(\frac{\pi d_1 \theta}{\lambda} \right) \right]$$

with A the incident amplitude, $S = \frac{\pi d^2}{4}$, $S_1 = \frac{\pi d_1^2}{4}$ and $\theta = \sqrt{\alpha^2 + \beta^2}$.

2. $I_0 = \left(\frac{|A|S}{\lambda z} \right)^2 \left(1 - \frac{S_1}{S} \right)^2$
4. With $d_1 = 0.5d$, the angular radius θ_1 of the first dark ring is the solution of $4\text{jinc} \left(\frac{\pi d \theta_1}{\lambda} \right) = \text{jinc} \left(\frac{\pi d \theta_1}{2\lambda} \right)$. From the table, we find $\theta_1 = \frac{\lambda}{d}$ ($1.22 \frac{\lambda}{d}$ without obstruction).
5. Intensity I_1 in the first bright ring, for $\theta = 1.6 \frac{\lambda}{d}$ (radius of the 1st bright ring without obstruction): $I_1 = 0.068 I_0$ (brighter than the situation without obstruction where $I_1 = 0.017 I_0$)

Ex. 1.7: Fraunhofer diffraction by a screen

1. The screen is a bright ring of radius $\frac{d}{2}$
2. Diffracted amplitude $f_z(\rho) = \frac{\pi A \alpha d e^{ikz}}{i \lambda z} J_0\left(\frac{\pi d \rho}{\lambda z}\right)$
3. Radius of the first bright ring: $0.76 \frac{\lambda z}{d}$ (circular aperture: $1.22 \frac{\lambda z}{d}$). Intensity I_1 of the first bright ring: $I_1/I(0) = 0.16$ (circular aperture: 0.017).

Ex. 1.8: Fraunhofer diffraction by a 2D periodic pattern

1. $t(x, y) = \Pi\left(\frac{\rho}{D}\right) \sin^2\left(\frac{\pi x}{a}\right) \cos^2\left(\frac{\pi y}{a}\right)$
2. Complex amplitude at $z = 0$: $f_0(x, y) = \psi_0 \Pi\left(\frac{\rho}{D}\right) \sin^2\left(\frac{\pi x}{a}\right) \cos^2\left(\frac{\pi y}{a}\right)$
3. Condition: $z \gg D^2/\lambda$
4. The diffracted amplitude contains 9 terms:

$$f_z(x, y) = \frac{\psi_0 S e^{ikz}}{2i \lambda z} \left[\text{jinc}\left(\frac{\pi d \rho}{\lambda z}\right) + \frac{1}{2} \text{jinc}\left(\frac{\pi d}{\lambda z} \sqrt{(x \pm \lambda z/a)^2 + y^2}\right) + \frac{1}{2} \text{jinc}\left(\frac{\pi d}{\lambda z} \sqrt{x^2 + (y \pm \lambda z/a)^2}\right) + \frac{1}{4} \text{jinc}\left(\frac{\pi d}{\lambda z} \sqrt{(x \pm \lambda z/a)^2 + (y \pm \lambda z/a)^2}\right) + \frac{1}{4} \text{jinc}\left(\frac{\pi d}{\lambda z} \sqrt{(x \mp \lambda z/a)^2 + (y \pm \lambda z/a)^2}\right) \right]$$

6. Intensity at the focal plane

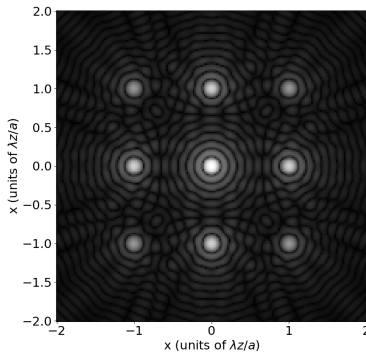

Ex. 1.9: bright filament

1. Illuminated by a plane wave, this object only allows light to pass through an infinitely thin slit: its appearance is that of a light filament.
2. ϵ is homogeneous to a length so that $t(x', y')$ is dimensionless .
3. $f_0(x', y') = A \epsilon \delta(x') \mathbf{1}(y')$
4. $f_D(x, y) = \frac{e^{ikD}}{i \lambda D} f_0 * \exp\left(\frac{i \pi (x^2 + y^2)}{\lambda D}\right)$

5. The function $f_D(x, y)$ can be written as $f_D(x, y) = \frac{e^{ikD}}{i \lambda D} A \epsilon \exp\left(\frac{i \pi x^2}{\lambda D}\right) \int_{-\infty}^{\infty} \exp\left(\frac{i \pi y^2}{\lambda D}\right) dy$

The integral on y is $\sqrt{i \lambda D}$ (can be calculated as the zero-value of a Fourier Transform). We obtain

$$f_D(x, y) = \frac{e^{ikD}}{\sqrt{i \lambda D}} A \epsilon \exp\left(\frac{i \pi x^2}{\lambda D}\right)$$

6. $f_D(x, y)$ does not depend on y . It is a cylindrical wave.
7. $\phi(x, y) = kD - \pi/4 + \frac{\pi x^2}{\lambda D}$ (the $\pi/4$ comes from the \sqrt{i} in the denominator).

8. $I_D(x, y) = \frac{|A|^2 \epsilon^2}{\lambda D}$ (it is constant and homogeneous to $|A|^2$).

9. In the $z = D$ plane, the complex amplitude of the plane wave is written as $\psi_D = B e^{-i\pi/4} e^{ikD}$. The resulting complex amplitude from its interference with f_D is written as:

$$B e^{-i\pi/4} e^{ikD} + A \epsilon \frac{e^{ikD - i\pi/4}}{\sqrt{\lambda D}} \exp\left(\frac{i\pi x^2}{\lambda D}\right)$$

10. The corresponding intensity in the case where A and B are real and $|B| \gg \frac{\epsilon}{\sqrt{\lambda D}} |A|$ is:

$$I(x, y) \simeq |B|^2 + \frac{2AB\epsilon}{\sqrt{\lambda D}} \cos\left(\frac{\pi x^2}{\lambda D}\right)$$

11. Maxima of intensity at $X_p = \sqrt{2p\lambda D}$; minima at $x_p = \sqrt{(2p+1)\lambda D}$ with p integer.

12. Contrast $\frac{2A\epsilon}{B\sqrt{\lambda D}}$

14. The phase $\phi(x, y)$ of the wave f_D is $\phi(x, y) = kD - \pi/4 + \frac{\pi x^2}{\lambda D}$: it is, up to an additive constant, the argument of the cosine involved in the intensity.

Exercises for chapter 2

Ex. 2.1: focal length of a telescope

1. Mask transmission: $t(x, y) = \Pi\left(\frac{\rho}{d}\right) \cos^2\left(\frac{\pi x}{a}\right)$

2. Amplitude at focal plane:

$$f(x, y) = B \left[2\text{jinc}\left(\frac{\pi d \rho}{\lambda F}\right) + \text{jinc}\left(\frac{\pi d}{\lambda F} \sqrt{\left(x + \frac{\lambda F}{a}\right)^2 + y^2}\right) + \text{jinc}\left(\frac{\pi d}{\lambda F} \sqrt{\left(x - \frac{\lambda F}{a}\right)^2 + y^2}\right) \right]$$

with $S = \frac{\pi d^2}{4}$ and $B = \frac{AS}{2i\lambda F} e^{2ikF}$

3. Peak positions: $(0, 0)$, $(\pm \frac{\lambda F}{a}, 0)$. Width: $\ell = 2.44\lambda F d$

4. Intensity: if $d \gg a$ the double products between terms in the amplitude vanish (as their width is \ll their separation). We obtain the sum of 3 Airy discs:

$$I(x, y) = |B|^2 \left[4\text{jinc}\left(\frac{\pi d \rho}{\lambda F}\right)^2 + \text{jinc}\left(\frac{\pi d}{\lambda F} \sqrt{\left(x + \frac{\lambda F}{a}\right)^2 + y^2}\right)^2 + \text{jinc}\left(\frac{\pi d}{\lambda F} \sqrt{\left(x - \frac{\lambda F}{a}\right)^2 + y^2}\right)^2 \right]$$

5. $\frac{\Delta F}{F} = \frac{1.22a}{5d} \simeq 0.02$

7. In polychromatic light, the peak width and separation increase with λ . The secondary peaks are dispersed.

Ex. 2.2: focusing screens

1. The screen transmission can be written as $t(x, y) = \frac{1}{2} + \frac{1}{4}L_F(x, y) + \frac{1}{4}L_{-F}(x, y)$ with L_F (resp. L_{-F}) the transmission of a converging (resp. diverging) lens of focal $F = \frac{a^2}{2\lambda}$.

2. Part of the light (1/4 of the amplitude) is focused by the term $L_F(x, y)$. Focal $F = \frac{a^2}{2\lambda}$

3. Red light: focal length $F = 17\text{m}$. Blue light: $F = 31\text{m}$. There is a very strong chromaticity. In white light one would observe a dispersion (rainbow) along the optical axis.

4. 1/16 of the incident intensity is focused (1/4 of the amplitude).

5. The plot shows that $t(X)$ is a Ronchi function, i.e. $t(X) = \sum_{n=-\infty}^{\infty} \prod \left(\frac{X - X_n}{a^2} \right)$ with $X_n = (2n + 1/2)a^2$. Applying the Poisson formula gives:

$$t(x, y) = \frac{1}{2a^2} \sum_{n=-\infty}^{\infty} i^n \operatorname{sinc} \left(\frac{\pi n}{2} \right) \exp \left(\frac{i\pi \rho^2}{\lambda F_n} \right)$$

with $F_n = \frac{a^2}{n\lambda}$. It is therefore a sum of converging (for $n < 0$) and diverging (for $n > 0$) lenses. Note that even terms excepted $n = 0$ are null (because of the sinc factor).

Ex. 2.3: diffraction grating

- e_1 and e_0 are lengths (same dimension as $e(x, y)$). a is also a length (same dimension as x to make sure that the argument of $\sin(2\pi \frac{x}{a})$ is dimensionless).
- Transmission: $t(x, y) = \Pi \left(\frac{x}{L} \right) \Pi \left(\frac{y}{L} \right) \exp \left(\frac{2i\pi(n-1)e_1}{\lambda} \sin \left(2\pi \frac{x}{a} \right) \right)$
- Amplitude at focal plane: $f(x, y) = \frac{AL^2}{i\lambda F} e^{2ikF} \sum_{p=-\infty}^{\infty} J_p \left(\frac{2\pi(n-1)e_1}{\lambda} \right) \operatorname{sinc} \left(\frac{\pi L}{\lambda F} (x - x_p) \right) \operatorname{sinc} \left(\frac{\pi Ly}{\lambda F} \right)$
- Peak positions: $x_p = \frac{p\lambda F}{a}$, $y_p = 0$. Width: $\frac{2\lambda F}{L}$
- Intensity: $I(x, y) = |f(x, y)|^2$. If $L \gg a$, the width of peaks \ll their separation, and they do not overlap (double products vanish in the sum). Hence:

$$I(x, y) \simeq \frac{|A|^2 L^4}{\lambda^2 F^2} \sum_{p=-\infty}^{\infty} J_p \left(\frac{2\pi(n-1)e_1}{\lambda} \right)^2 \operatorname{sinc} \left(\frac{\pi L}{\lambda F} (x - x_p) \right)^2 \operatorname{sinc} \left(\frac{\pi Ly}{\lambda F} \right)^2$$

- $R_p = \left(\frac{J_p(X)}{J_0(X)} \right)^2$ with $X = \frac{2\pi(n-1)e_1}{\lambda}$
- If $e_1/\lambda \ll 1$ then $R_p \simeq \frac{1}{p!^2} (\pi(n-1))^{2p} \left(\frac{e_1}{\lambda} \right)^{2p}$
- $R_2 < 0.01$ if $e_1 < 0.14\lambda$

Ex. 2.4: cylindrical lens

- Axis Δ parallel to y (the transmission coefficient is independent of y)
- $M(x, y) = \exp \left(\frac{i\pi y^2}{\lambda F} \right)$ so that the product $L_F(x, y)M(x, y)$ is $C_F(x, y)$. $M(x, y)$ corresponds to a diverging cylindrical lens (with curvature along the y direction).
- To calculate the amplitude at $z = F$, we consider the equivalent problem of an object of transmission $M(x, y)$ in front of a converging lens L_F . Therefore, the amplitude is the optical Fourier transform of $AM(x, y)$. We obtain:
 $f(x, y) = \frac{A\sqrt{\lambda F}}{\sqrt{i}} e^{ikF} \delta(x) \mathbf{1}(y)$. It is a bright line parallel to the y axis.
- Lens spatially limited: $M(x, y)$ is multiplied by $\Pi \left(\frac{x}{d} \right)$. The new amplitude in the focal plane is:

$$f'(x, y) = \frac{Ad}{\sqrt{i\lambda F}} e^{ikF} e^{\frac{i\pi x^2}{\lambda F}} \operatorname{sinc} \left(\frac{\pi dx}{\lambda F} \right) \mathbf{1}(y)$$

Ex. 2.5: Apodized grating

- Mask transmission: $t(x, y) = \text{III}_a(x) \Lambda \left(\frac{2x}{L} \right) \prod \left(\frac{y}{L} \right)$. Complex amplitude at $z = 0$: $f_0(x, y) = \psi_0 \text{III}_a(x) \Lambda \left(\frac{2x}{L} \right) \prod \left(\frac{y}{L} \right)$
- Amplitude at $z = 2F$: $f_{2F}(x, y) = \frac{\psi_0 L^2 e^{2ikF}}{2ia\lambda F} \operatorname{sinc} \left(\frac{\pi Ly}{\lambda F} \right) \sum_n \operatorname{sinc}^2 \left[\frac{\pi L}{2\lambda F} \left(x - \frac{n\lambda F}{a} \right) \right]$
- Order n : position $\frac{n\lambda F}{a}$, width $\frac{4\lambda F}{L}$ independent of n .
- The 2D image is made of spots of width $\frac{4\lambda F}{L}$ in the x direction and $\frac{2\lambda F}{L}$ (two times smaller) in the y direction. The secondary maxima have a larger amplitude in the y direction (sinc function versus sinc²). Compared to the gate function, the triangle $t_p(x)$ enlarges the peaks, and reduces the secondary maxima (apodization technique).

Ex. 2.6: Lens lit by a point-source

1. Transmission coefficient of the lens: $t(x, y) = \exp\left(-\frac{i\pi\rho^2}{\lambda F}\right)$, where $\rho^2 = x^2 + y^2$.
2. Before passing through the lens: $f_{p-}(x, y) = \frac{\psi_0}{p} e^{ikp} \exp\left(\frac{i\pi\rho^2}{\lambda p}\right)$

Att the output of the lens ($z = p^+$) with $p = F$: $f_{p+}(x, y) = \frac{\psi_0}{F} e^{ikF}$

The amplitude is constant in the $z = p^+$ plane: we are dealing with a plane wave propagating parallel to \hat{z} .

3. We assume $p = F$ and $x_0 > 0$.

(a) Paraxial approximation when $p \gg (x_0^4/\lambda)^{1/3}$

(b) Complex amplitude at $z = p^-$ before lens: $f_{p-}(x, y) = \frac{\psi_0}{p} e^{ikp} \exp\left(\frac{i\pi[(x-x_0)^2 + y^2]}{\lambda p}\right)$

and at the output of the lens ($z = p^+$) with $p = F$: $f_{p+}(x, y) = Cte \exp\left(\frac{2i\pi}{\lambda}\alpha x\right)$

where $\alpha = -x_0/F$. This is the amplitude of a plane wave, with inclined incidence and wave vector $\vec{k} = (-\frac{x_0}{F}, 0, \gamma)$ where $\gamma = \sqrt{1-\alpha^2}$.

4. We assume $x_0 = 0$ and $p > F$.

(a) Complex amplitude lens output ($z = p^+$): $f_{p+}(x, y) = \frac{\psi_0}{p} e^{ikp} \exp\left[\frac{i\pi\rho^2}{\lambda}\left(\frac{1}{p} - \frac{1}{F}\right)\right]$

The phase is in ρ^2 , characteristic of a spherical wave in the paraxial approximation.

(b) It is convergent because the sign of $\left(\frac{1}{p} - \frac{1}{F}\right)$ is negative. It converges to a point with coordinates (x_s, y_s, z_s) where $z_s > p$ (if the wave propagates towards $z > 0$). This point is in fact the geometric image of the source by the lens.

(c) To find the center (x_s, y_s, z_s) of the spherical wave $f_{p+}(x, y)$, we identify in the general case:

$$f_p(x, y) = Cte \exp\left(\frac{i\pi[(x-x_s)^2 + (y-y_s)^2]}{\lambda|z-z_s|}\right)$$

with $z = p$. Thus, $x_s = y_s = 0$ (the center of the wave is on the axis), and $\frac{1}{|p-z_s|} = \frac{1}{F} - \frac{1}{p}$

that is, $z_s = \frac{p^2}{p-F}$ given $z_s > p$.

(d) From the above equality: $\frac{1}{|p-z_s|} = \frac{1}{p'} = \frac{1}{F} - \frac{1}{p}$

we deduce the conjugation formula: $\frac{1}{p} + \frac{1}{p'} = \frac{1}{F}$

Exercises for chapter 3

Ex. 3.1: filtering of periodic patterns

1. Amplitude in filtering plane: $f_b(x, y) = A \frac{e^{2ikF}}{i\lambda F} \hat{t}\left(\frac{x}{\lambda F}, \frac{y}{\lambda F}\right) \cdot P(x, y)$
2. Amplitude in the image plane: $f(x, y) = -Ae^{4ikF} t(-x, -y) * \frac{1}{\lambda^2 F^2} \hat{P}\left(\frac{x}{\lambda F}, \frac{y}{\lambda F}\right)$
3. Image uniform if $D < \frac{2\lambda F}{a}$. PSF size $\ell = 2.44 \frac{\lambda F}{D}$.
4. We want the grid #5 to be filtered but not the grid #4. This gives $0.82\text{mm} < D < 0.93\text{mm}$. If $\lambda = 500\text{nm}$, only the grid #6 is filtered.
5. Siemens star:
 - (a) Spatial period: $a(\rho) = \frac{2\pi\rho}{N}$
 - (b) Low-pass filter: the center of the star is filtered (uniform). $\Delta = \frac{2N\lambda F}{\pi D}$
 - (c) $D = 2.7\text{mm}$

Ex. 3.2: high-pass optical filtering

1. A negative transmission of -1 corresponds to a phase shift of π . Hence to obtain a negative transmission $-bx$, one has to use an absorbing filter (transmission $b|x|$) and a parallel plate of transmission $e^{i\pi}$.
2. High-pass
3. Amplitude in filtering plane: $f_b(x, y) = \frac{Abde^{2ikF}}{i\pi} \text{sinc}\left(\frac{\pi dy}{\lambda F}\right) \sin\left(\frac{\pi dx}{\lambda F}\right)$
4. Amplitude in image plane: $f(x, y) = \frac{Ab\lambda F e^{4ikF}}{2i\pi} \text{II}\left(\frac{y}{d}\right) \left[\delta\left(x + \frac{d}{2}\right) - \delta\left(x - \frac{d}{2}\right)\right]$
5. If $P(x, y)$ is multiplied by $\text{II}\left(\frac{x}{\ell}\right) \cdot \text{II}\left(\frac{y}{\ell}\right)$, the amplitude in the image plane become:

$$f(x, y) = (Cte) \text{II}\left(\frac{y}{d}\right) \left[\text{sinc}\left(\frac{\pi\ell}{\lambda F}\left(x + \frac{d}{2}\right)\right) - \text{sinc}\left(\frac{\pi\ell}{\lambda F}\left(x - \frac{d}{2}\right)\right)\right]$$

with (Cte) a multiplicative constant.

Ex. 3.3 image replication

1. Amplitude in the image plane: $f(x, y) = -\frac{1}{G} e^{2ik(F+F_2)} f_0\left(-\frac{x}{G}, -\frac{y}{G}\right) * \frac{1}{\lambda^2 F_2^2} \hat{P}\left(\frac{x}{\lambda F_2}, \frac{y}{\lambda F_2}\right)$ with $f_0(x, y) = Ap(x, y)$ the amplitude in the object plane, and $G = \frac{F_2}{F}$ a magnification factor (main difference with the case $F_2 = F$).
2. $P(x, y) = (Cte) \text{III}_b(x) \cdot \text{III}_b(y)$ where (Cte) is an optional multiplicative constant (useful to make $P(x, y)$ dimensionless).
3. Amplitude PSF: $h(x, y) = \frac{1}{\lambda^2 F_2^2} \text{III}\left(\frac{bx}{\lambda F_2}\right) \text{III}\left(\frac{by}{\lambda F_2}\right)$. Period $\frac{\lambda F_2}{b}$ in both directions.
4. Amplitude in image plane: $f(x, y) = -\frac{AG e^{2ik(F+F_2)}}{\lambda^2 F_2^2} p\left(-\frac{x}{G}, -\frac{y}{G}\right) * \text{III}\left(\frac{bx}{\lambda F_2}\right) \text{III}\left(\frac{by}{\lambda F_2}\right)$. It is a periodic replication (period $\frac{\lambda F_2}{b}$) of a magnified pentagon of size aG .
5. No overlap if $b < \frac{\lambda F}{a}$

Ex. 3.4 optical filtering with coherent and incoherent light

1. $f_c(x, y) = -e^{4ikF} f_A(-x, -y) * \frac{2s}{\lambda^2 F^2} \text{jinc}\left(\frac{\pi d\rho}{\lambda F}\right)$ with $f_A(x, y) = \psi_0 t(x, y)$, $s = \pi d^2/4$ and $\rho = \sqrt{x^2 + y^2}$
2. Amplitude PSF: $h(x, y) = \frac{2s}{\lambda^2 F^2} \text{jinc}\left(\frac{\pi d\rho}{\lambda F}\right)$. Transfer function: $\hat{h}(u, v) = \text{II}\left(\frac{q\lambda F}{d}\right)$ with $q = \sqrt{u^2 + v^2}$
3. $f_c = \frac{d}{2\lambda F}$
4. $I(x, y) = (Cte) |\psi_0|^2 \left[h\left(x - \frac{x_0}{2}\right) + h\left(x + \frac{x_0}{2}\right)\right]^2$
5. Uniform image if $m > f_c$
6. Image uniform for $x > (f_c - m_0)/b$
7. Intensity PSF: $S(x, y) = |h(x, y)|^2$
8. $T(u, v) = \text{II}\left(\frac{\lambda F q}{d}\right)$
9. $f_c = \frac{d}{\lambda F}$ two times larger than the coherent case
10. $I(x, y) = (Cte) |\psi_0|^2 \left[h\left(x - \frac{x_0}{2}\right)^2 + h\left(x + \frac{x_0}{2}\right)^2\right]$. The difference with the coherent case is that there is no double product. The object is best resolved with incoherent light.
11. If $t(x, y) = \frac{1}{2} + \frac{1}{2} \cos(2\pi mx)$, then $I(x, y) = (Cte) \left[1 + \text{II}\left(\frac{\lambda F m}{d}\right) \cdot \cos(2\pi mx)\right]$. Contrast: $C = \text{II}\left(\frac{\lambda F m}{d}\right)$. Uniform image if $m > \frac{d}{\lambda F}$
12. Contrast $C(x) = \text{II}\left(\frac{\lambda F(m_0 + bx)}{d}\right)$.

Ex. 3.5: optical filtering by a pair of holes

- Amplitude in the filtering plane: $f_1(x, y) = \frac{Ae^{2ikF}}{i\lambda F} \hat{t}\left(\frac{x}{\lambda F}, \frac{y}{\lambda F}\right) \cdot P(x, y)$.
Amplitude in image plane: $f(x, y) = -Ae^{4ikF} t(-x, -y) * \frac{1}{\lambda^2 F^2} \hat{P}\left(\frac{x}{\lambda F}, \frac{y}{\lambda F}\right)$
- $h(x, y) = \frac{1}{\lambda^2 F^2} \hat{P}\left(\frac{x}{\lambda F}, \frac{y}{\lambda F}\right)$. $\hat{h}(u, v) = P(-\lambda Fu, -\lambda Fv)$.
- Intensity $\neq 0$ if $\frac{d}{2\lambda F} < m < \frac{3d}{2\lambda F}$. Bandpass filter.
- Intensity in the above case: $I(x, y) = |A|^2 \cos^2(2\pi mx)$
- Image uniform if $x > \frac{1}{K} \left(\frac{3d}{2\lambda F} - m_0\right)$ or $x < \frac{1}{K} \left(\frac{d}{2\lambda F} - m_0\right)$
- New transfer function: $\hat{h}(u, v) = \Pi\left(\frac{q\lambda F}{d}\right) * \left[\delta\left(u - \frac{d}{\lambda F}, v\right) - \delta\left(u + \frac{d}{\lambda F}, v\right)\right]$. Cutoff frequencies unchanged: $u_c = \pm \frac{d}{2\lambda F}, \pm \frac{3d}{2\lambda F}$
- New intensity: $I(x, y) = |A|^2 \sin^2(2\pi mx)$. There is a half period shift of the fringes.

Ex. 3.6: Coherent optical filtering

- $P(x, y) = \Pi\left(\frac{x}{d/2}\right) \cdot \Pi\left(\frac{y}{d}\right) * \left[\delta\left(x - \frac{d}{4}, y\right) - \delta\left(x + \frac{d}{4}, y\right)\right]$
- On-axis point source
 - $f_0(x, y) = b\delta(x, y)$ with b a constant (for dimensional purpose).
 - Amplitude in plane (B): $f_1(x, y) = \frac{e^{2ikF}}{i\lambda F} \hat{f}_0\left(\frac{x}{\lambda F}, \frac{y}{\lambda F}\right) \cdot P(x, y) = \frac{be^{2ikF}}{i\lambda F} P(x, y)$ with $k = \frac{2\pi}{\lambda}$
 - Amplitude in plane (C): $f_2(x, y) = \frac{e^{2ikF}}{i\lambda F} \hat{f}_1\left(\frac{x}{\lambda F}, \frac{y}{\lambda F}\right) = -\frac{be^{4ikF}}{\lambda^2 F^2} \hat{P}\left(\frac{x}{\lambda F}, \frac{y}{\lambda F}\right)$ The FT of $P(x, y)$ is $\hat{P}(u, v) = -id^2 \text{sinc}(\pi vd) \cdot \text{sinc}\left(\pi u \frac{d}{2}\right) \cdot \sin\left(\pi u \frac{d}{2}\right)$ We obtain $f_2(x, y) = \frac{ibd^2 e^{4ikF}}{\lambda^2 F^2} \text{sinc}\left(\frac{\pi yd}{\lambda F}\right) \cdot \text{sinc}\left(\frac{\pi xd}{2\lambda F}\right) \cdot \sin\left(\frac{\pi xd}{2\lambda F}\right)$ The intensity is $I_2(x, y) = I_0 \text{sinc}\left(\frac{\pi yd}{\lambda F}\right)^2 \cdot \text{sinc}\left(\frac{\pi xd}{2\lambda F}\right)^2 \cdot \sin\left(\frac{\pi xd}{2\lambda F}\right)^2$ with $I_0 = \frac{b^2 d^4}{\lambda^4 F^4}$
 - The on-axis intensity value is 0.
- Periodic grid

(a) Amplitude in plane (B), before the pupil: $f_{1-}(x, y) = -\frac{i}{2} \psi_0 \lambda F e^{2ikF} \delta\left(x \pm \frac{\lambda F}{a}, y\right)$

(b) The amplitude $f_{1-}(x, y)$ is composed of two delta distributions which will be bloqued by the pupil edges if $\frac{\lambda F}{a} > d/2$. The condition to see a non-uniform image is then $a > \frac{2\lambda F}{d}$

(c) The amplitude in plane (B) just after the pupil is $f_1(x, y) = -\frac{i}{2} \psi_0 \lambda F e^{2ikF} [\delta(x - \frac{\lambda F}{a}, y) - \delta(x + \frac{\lambda F}{a}, y)]$. In the place (C), the amplitude is then

$$f_2(x, y) = i\psi_0 e^{4ikF} \sin\left(\frac{2\pi x}{a}\right)$$

and the intensity is $I_2(x, y) = |\psi_0|^2 \sin^2\left(\frac{2\pi x}{a}\right)$. The optical axis is located on a dark fringe ($I_2(0, 0) = 0$).

(d) If there is no parallel plate on the pupil, the amplitude in the plane (C) is simply proportional to $f_0(x, y)$ and the intensity $I_2'(x, y) = |\psi_0|^2 \cos^2\left(\frac{2\pi x}{a}\right)$. The difference between the two functions is a half-period shift (swap between dark and bright fringes).

Ex. 3.7: Phase contrast

- We have a double diffraction optical setup with identical lenses, so in the image plane, the amplitude is proportional to $\hat{f}_0(x, y) = f_0(-x, -y)$ where $f_0(x, y)$ is the amplitude in the object plane. So the intensity is propotional to $|f_0|^2$, which is constant (the phase term $e^{i\varphi}$ due to the plate has no effect on the intensity). We then observe a uniform image in the image plane.
- $\varphi = \frac{2\pi}{\lambda}(n-1)e \simeq 0.01$ rad

3. The transmission coefficient $t(x, y)$ is 1 outside the plate, and $e^{i\varphi}$ inside. It takes the form:

$$t(x, y) = 1 + \Pi\left(\frac{x}{a}\right) \Pi\left(\frac{y}{a}\right) (e^{i\varphi} - 1) \simeq 1 + i\varphi \Pi\left(\frac{x}{a}\right) \Pi\left(\frac{y}{a}\right)$$

4. Start with $f_1(x, y) = \frac{e^{2ikF}}{i\lambda F} A \hat{t}\left(\frac{x}{\lambda F}, \frac{y}{\lambda F}\right)$. We obtain:

$$f_1(x, y) = \frac{Ae^{2ikF}}{i\lambda F} \left[(\lambda F)^2 \delta(x, y) + i\varphi a^2 \operatorname{sinc}\left(\frac{\pi ax}{\lambda F}\right) \operatorname{sinc}\left(\frac{\pi ay}{\lambda F}\right) \right]$$

5. The width of the diffracted amplitude is the width of the sinc term, its size (distance between the two first zeros around the center) is $2\lambda F/a \simeq 12$ cm.

6. plot of $f_1(x, 0)$:

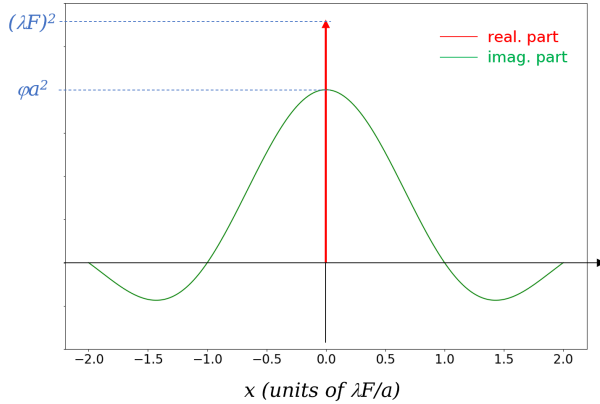

7. The circular plate multiplies the central peak by $i\tau$, with almost no effect on the sinc term. The amplitude becomes

$$f_{1+}(x, y) = \frac{Ae^{2ikF}}{i\lambda F} \left[i\tau (\lambda F)^2 \delta(x, y) + i\varphi a^2 \operatorname{sinc}\left(\frac{\pi ax}{\lambda F}\right) \operatorname{sinc}\left(\frac{\pi ay}{\lambda F}\right) \right]$$

8. At the first order in φ , we have

$$I_2(x, y) = |A|^2 \left(\tau^2 + 2\varphi\tau \Pi\left(\frac{x}{a}\right) \Pi\left(\frac{y}{a}\right) \right)$$

9. Plot of $I_2(x, 0)$ (left) and aspect of the image (right) in the image plane:

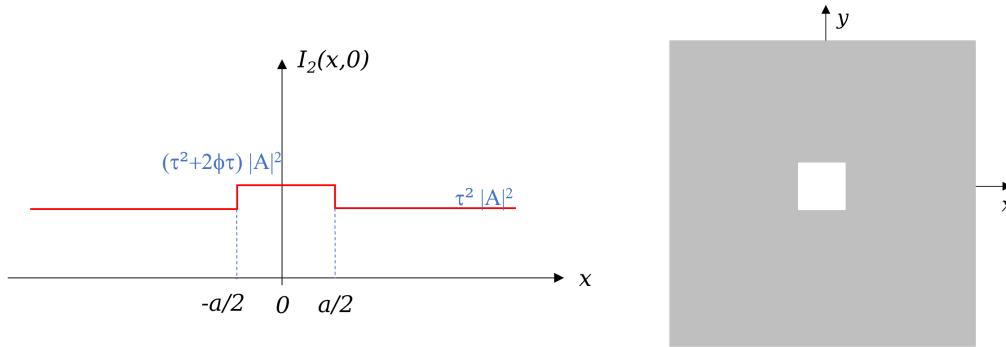

Aspect of the image

The image now shows a bright square at the center, and a uniform background. The bright square is the signature of the phase object, which is now visible on the intensity, thanks to the circular phase plate in the filtering plane (it was not the case in question 1, where the intensity was uniform).

10. Contrast $C = \frac{\varphi}{\tau + \varphi}$. To have $C = 10\%$, we need $\tau = 9\varphi$.

Exercises for chapter 4

Ex. 4.1: Image of a double star and pupil apodization

1. Intensity PSF: $S(\alpha, \beta) = 4s^2 \text{jinc}\left(\frac{\pi d \theta}{\lambda}\right)^2$ with $s = \frac{\pi d^2}{4}$ and $\theta = \sqrt{\alpha^2 + \beta^2}$
2. $\theta_0 = 1.22 \frac{\lambda}{d}$
3. $I(\alpha, \beta) = I_1(\alpha, \beta) + I_2(\alpha, \beta)$ with $I_1(\alpha, \beta) = AS(\alpha, \beta)$ and $I_2(\alpha, \beta) = rAS(\alpha + \phi, \beta)$
6. The plot shows that images are well resolved if $\phi = \theta_0$ and “just resolved” if $\phi = \frac{\lambda}{d}$. So the limit of resolution is $\frac{\lambda}{d}$.
8. Numeric values are $I_2(-\phi, 0) = 10^{-3} As^2$ and $I_1(-\phi, 0) = 2.4 \cdot 10^{-3} As^2$. The intensity produced by the main star (I_1) is greater than the intensity produced by the companion.
9. The plot of the apodized pupil shows a discontinuity of about 0.02 at the pupil edges. This is small enough to be neglected.
10. PSF: $S(\alpha, \beta) = \pi^2 w^4 \exp\left(-\frac{2\pi^2 w^2 \theta^2}{\lambda^2}\right)$. $\Delta = 1.5 \frac{\lambda}{d}$ larger than θ_0 so there is a loss of resolution with the apodization.
12. Numeric values are $I_2(-\phi, 0) = 10^{-3} \pi Aw^2$ and $I_1(-\phi, 0) = 2.9 \cdot 10^{-5} \pi Aw^2$. The companion is now brighter than the main star.
13. If pupil edges are not neglected: $S(\alpha, \beta) = (Cte) \left[\text{jinc}\left(\frac{\pi d \theta}{\lambda}\right) * \exp\left(-\frac{\pi^2 w^2 \theta^2}{\lambda^2}\right) \right]^2$ with (Cte) a multiplicative constant.

Ex. 4.2: Measurement of the angular diameter of a star

1. PSF: $S(\alpha, \beta) = 4 \cos^2\left(\frac{\pi d \alpha}{\lambda}\right)$
2. Intensity in the focal plane: $I(\alpha, \beta) = I_0(-\alpha, -\beta) * S(\alpha, \beta)$ with $I_0(\alpha, \beta) = \Pi\left(\frac{\theta}{\theta_0}\right)$
3. $I(\alpha, \beta) = \frac{\pi \theta_0^2}{2} \left[1 + 2 \text{jinc}\left(\frac{\pi \theta_0 d}{\lambda}\right) \cdot \cos\left(\frac{2\pi \alpha d}{\lambda}\right) \right]$
4. Fringe contrast: $C = |2 \text{jinc}\left(\frac{\lambda}{ad}\right)|$. $C = 0$ for all zeros of the jinc function. The first zero is for $d = 1.22 \frac{\lambda}{\theta_0}$, allowing to measure θ_0 (the method is to change d until the image becomes uniform).
5. I2T: smallest value $\theta_0 = 0.9$ milli-arcsec.

Ex. 4.3: Image of a sinusoidal grid

1. Intensity at focal plane: $I(\alpha, \beta) = \frac{1}{2} + \frac{1}{2} \cos\left(\frac{2\pi \alpha}{a}\right)$
3. Diameter $d_1 = 2.47\text{m}$
4. For $\lambda = 400\text{nm}$, the contrast is $C = 0.22$
5. Square pupil transfer function: $T(u, v) = \Lambda\left(\frac{u\lambda}{d}\right) \cdot \Lambda\left(\frac{v\lambda}{d}\right)$. Cutoff frequencies $u_c = v_c = \frac{d}{\lambda}$, identical to the circular pupil: both telescopes have the same resolution.
6. Contrast for the square pupil at $\lambda = 400\text{nm}$: $C = 0.33$ (better contrast than circular pupil).

Ex. 4.4: Diluted pupil with two circular apertures

1. PSF: $S(\alpha, \beta) = 16s^2 \cos^2\left(\frac{\pi B \alpha}{\lambda}\right) \cdot \text{jinc}\left(\frac{\pi \theta d}{\lambda}\right)^2$ with $s = \frac{\pi d^2}{4}$ and $\theta = \sqrt{\alpha^2 + \beta^2}$
3. Fringe number: $N = 2.44 \frac{B}{d}$
4. Intensity in the image: $I(\alpha, \beta) = A \left[S(\alpha - \frac{\Delta}{2}, \beta) + S(\alpha + \frac{\Delta}{2}, \beta) \right]$ with A a constant for dimension purpose ($A =$ intensity of individual stars).

- Transfer function $T(u, v) = \text{circ}\left(\frac{q\lambda}{d}\right) + \frac{1}{2} \text{circ}\left(\frac{\lambda}{d} \sqrt{\left(u - \frac{B}{\lambda}\right)^2 + v^2}\right) + \frac{1}{2} \text{circ}\left(\frac{\lambda}{d} \sqrt{\left(u + \frac{B}{\lambda}\right)^2 + v^2}\right)$ with $q = \sqrt{u^2 + v^2}$.
Cutoff frequencies: $u_c = \frac{B+d}{\lambda}$, $v_c = \frac{d}{\lambda}$
- In the u direction, the telescope has the same cutoff frequency (so the same resolution) than a telescope of diameter $B + d$.
- If $B < 2d$ the 3 terms of the transfer function overlap, and the transfer function has no zero in the interval $u \in [-u_c, u_c]$

Ex. 4.5 study of a defocus aberration

- The lens transmission expresses as $t(x, y) = \exp\left(-\frac{i\pi\rho^2}{\lambda F'}\right)$ ($\rho = \sqrt{x^2 + y^2}$) with $F' \simeq F + \epsilon F^2$. If $\epsilon > 0$: intrafocal (images are observed at a distance $F < F'$ from the telescope pupil).
- $w = \epsilon d^2/8$
- $S(\alpha, \beta) = (Cte) \left[\text{sinc}\left(\frac{\pi\alpha d}{\lambda}\right) \cdot \text{sinc}\left(\frac{\pi\beta d}{\lambda}\right) * \exp\left(-\frac{i\pi\theta^2}{\lambda\epsilon}\right) \right]^2$ with $\theta = \sqrt{\alpha^2 + \beta^2}$
- $T(u, v) = \frac{1}{d^2} \frac{\sin(\pi\epsilon u(d - \lambda|u|))}{\pi\epsilon u} \frac{\sin(\pi\epsilon v(d - \lambda|v|))}{\pi\epsilon v}$
- $u_c = v_c = d/\lambda$
- Limit $\epsilon \rightarrow \infty$: $T(u, v) \simeq \Lambda\left(\frac{u\lambda}{d}\right) \cdot \Lambda\left(\frac{v\lambda}{d}\right)$
- Object intensity distribution: $I_0(\alpha, \beta) = (Cte) \cos^2\left(\frac{\pi\alpha}{\alpha_0}\right)$ with $\alpha_0 = a/D$. Image contrast: $C = |T(\frac{1}{\alpha_0}, 0)|$. $C = 0$ for $a = a_1 = 1.4\frac{D\lambda}{d}$ and $a = a_2 = 3.4\frac{D\lambda}{d}$. If $a_1 < a < a_2$ the signed visibility $T(\frac{1}{\alpha_0}, 0) < 0$ resulting in a contrast reversal.

Ex. 4.6: rectangular pupil with phase shift

- Pupil function: $P(x, y) = \Pi\left(\frac{x}{b}\right) \left[\Pi\left(\frac{y}{a}\right) * \left(\delta\left(y + \frac{a}{2}\right) - \delta\left(y - \frac{a}{2}\right) \right) \right]$.
PSF: $S(\alpha, \beta) = (Cte) \cdot \text{sinc}\left(\frac{\pi\alpha b}{\lambda}\right)^2 \cdot \text{sinc}\left(\frac{\pi\beta a}{\lambda}\right)^2 \cdot \sin\left(\frac{\pi\beta a}{\lambda}\right)^2$
- First method: calculate the Fourier transform of $S(\alpha, \beta)$. Second method: make use of the pupil autocorrelation $C_P(X, Y)$ and express it as the convolution $C_P(X, Y) = P(-X, -Y) * \overline{P(X, Y)}$.
One obtains $T(u, v) = \Lambda\left(\frac{u\lambda}{b}\right) \cdot \left[\Lambda\left(\frac{v\lambda}{a}\right) - \frac{1}{2} \Lambda\left(\frac{\lambda}{a}\left(v - \frac{\lambda}{a}\right)\right) - \frac{1}{2} \Lambda\left(\frac{\lambda}{a}\left(v + \frac{\lambda}{a}\right)\right) \right]$

Ex. 4.7: a simple pistonscope

- $\phi = 2\pi\delta/\lambda$
- $P(x, y) = \Pi\left(\frac{\rho}{d}\right) * \left(e^{i\phi} \delta\left(x - \frac{a}{2}, y\right) + \delta\left(x + \frac{a}{2}, y\right) \right)$ with $\rho = \sqrt{x^2 + y^2}$
- $S(\alpha, \beta) = 8s^2 \text{jinc}\left(\frac{\pi\theta d}{\lambda}\right)^2 \cdot \left[1 + \cos\left(\frac{2\pi\alpha a}{\lambda} - \phi\right) \right]$ with $s = \frac{\pi d^2}{4}$ and $\theta = \sqrt{\alpha^2 + \beta^2}$
- Fringe number: $N = 2.44a/d$
- The cosine term in S is $\cos\left(\frac{2\pi a}{\lambda}(\alpha - \Delta)\right)$ with $\Delta = \delta/a$
- We want $\Delta = p/F$ so $\delta = ap/F$
- $T(u, v) = \text{circ}\left(\frac{a\lambda}{d}\right) * \left[\delta(u, v) + \frac{1}{2} \delta\left(u - \frac{a}{\lambda}, v\right) e^{-i\phi} + \frac{1}{2} \delta\left(u + \frac{a}{\lambda}, v\right) e^{i\phi} \right]$. It is a complex function (the complex terms $e^{\pm i\phi}$ vanish if $\phi = 0$)
- Angular resolution=cutoff period= $\lambda/(a + d)$. Independent of ϕ
- Non-uniform image if $\ell > \frac{\lambda D}{d}$ (N.A.: 5mm), or if $\frac{\lambda D}{(a+d)} < \ell < \frac{\lambda D}{(a-d)}$ (NA: 0.15mm $< \ell < 0.55$ mm)

Ex: 4.8: circular disc with limb darkening

1. $P(x, y) = \delta(x - \frac{B}{2}, y) + \delta(x + \frac{B}{2}, y)$
2. $S(\alpha, \beta) = 4 \cos^2 \left(\frac{\pi \alpha B}{\lambda} \right)$
3. Transfer function $T(u, v) = 2\delta(u, v) + \delta(u - \frac{B}{\lambda}, v) + \delta(u + \frac{B}{\lambda}, v)$ Accessible frequencies: $(u, v) = (0, 0)$ and $(\pm \frac{B}{\lambda}, 0)$
4. $I(\alpha, \beta) = 2\hat{I}_0(0, 0) + 2\hat{I}_0(\frac{B}{\lambda}, 0) \cdot \cos \left(\frac{2\pi \alpha B}{\lambda} \right)$. Fringes of angular period λ/B .
5. Contrast: $C = \left| \frac{\hat{I}_0(\frac{B}{\lambda}, 0)}{\hat{I}_0(0, 0)} \right|$
6. $V_1(B) = 2 \left| \text{jinc} \left(\frac{\pi \theta_0 B}{\lambda} \right) \right|$
7. $V_1 = 0$ for $B = 1.22\lambda/\theta_0$. By varying B , one can look for a uniform image and deduce θ_0 .
8. $B_m = 1.6\lambda/\theta_0$. $V_1(B_m) = 0.12$.
9. $V_2(B) = V_1(B) \cdot \exp \left(-\frac{\pi^2 L^2 B^2}{\lambda^2} \right)$. $V_2(B_m) = 0.12 \exp \left(-\frac{\pi^2 L^2 1.6^2}{\theta_0^2} \right)$.
10. Measure the ratio of the two visibilities: $R = \frac{V_2}{V_1} = \exp \left(-\frac{\pi^2 L^2 B^2}{\lambda^2} \right)$. B and λ are known, so one can deduce L .

Ex: 4.9: Circumstellar ring

1. $P(x, y) = C^{te} \delta \left(x \pm \frac{B}{2}, y \right)$
with C^{te} a multiplicative factor (equal to the surface of individual apertures, which makes $P(x, y)$ dimensionless)

2. $S(\alpha, \beta) = \left| \hat{P} \left(\frac{\alpha}{\lambda}, \frac{\beta}{\lambda} \right) \right|^2 = K \cos^2 \left(\frac{\pi \alpha B}{\lambda} \right)$ with K a constant factor

3. $T(u, v) = \hat{S}(u, v) = \frac{K}{2} \left[\delta(u, v) + \frac{1}{2} \delta \left(u \pm \frac{B}{\lambda}, v \right) \right]$. Accessible angular frequencies $(u, v) = (0, 0), (\pm \frac{B}{\lambda}, 0)$

4. Use the object-image relation in the Fourier plane: $\hat{I}(u, v) = \hat{I}_0(-u, -v) \cdot T(u, v)$.
The Fourier Transform of I_0 is

$$\hat{I}_0(u, v) = 2\pi A \varphi J_0(2\pi q \varphi)$$

with $q = [u^2 + v^2]^{1/2}$. We obtain:

$$\hat{I}(u, v) = K' \left[J_0(0) \delta(u, v) + \frac{1}{2} J_0 \left(2\pi \frac{B}{\lambda} \varphi \right) \delta \left(u \pm \frac{B}{\lambda}, v \right) \right]$$

with K' a constant. The intensity in the image is:

$$I(\alpha, \beta) = K' \left[1 + J_0 \left(2\pi \frac{B}{\lambda} \varphi \right) \cos \left(\frac{2\pi \alpha B}{\lambda} \right) \right]$$

5. The only term depending on the variables α, β is $\cos \left(\frac{2\pi \alpha B}{\lambda} \right)$ which correspond to fringes periodic in the α direction, with a period $\frac{\lambda}{B}$ as for the PSF.

6. The contrast is $C = \frac{I_{\max} - I_{\min}}{I_{\max} + I_{\min}}$, with $I_{\max} = K' [1 + |J_0(2\pi \frac{B}{\lambda} \varphi)|]$ and $I_{\min} = K' [1 - |J_0(2\pi \frac{B}{\lambda} \varphi)|]$. We get

$$C(B) = \left| J_0 \left(2\pi \frac{B}{\lambda} \varphi \right) \right|$$

7. From the graph, we see that $J_0(x) = 0$ for $x \simeq 2.4$. This gives $B_1 \simeq 0.4 \frac{\lambda}{\varphi}$.
8. The contrast reversal is a swap between bright and dark fringes. It is observed when the visibility function $J_0(2\pi \frac{B}{\lambda} \varphi)$ is negative. In our case, it happens for $B_1 < B < 0.87 \frac{\lambda}{\varphi}$.

9. For $B = B_1/2$ the contrast is $C(B) \simeq 0.7$. The intensity plot $I(\alpha, 0)/K'$ is shown below, together with the normalized PSF $S(\alpha, 0)/K$. The fringe period is the same as the PSF, the only difference is the contrast (dark fringes have zero intensity for the PSF, not for the image).

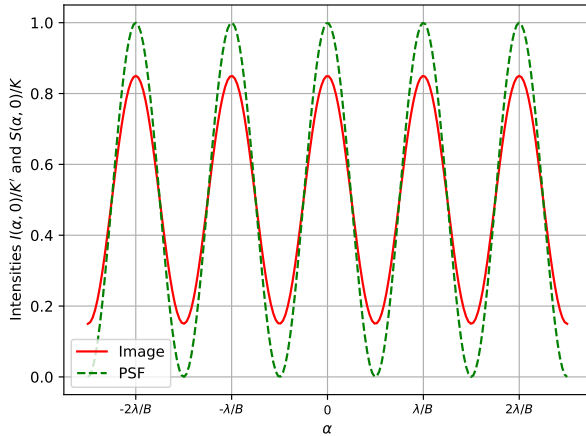

10. Numerical application: $\varphi \simeq 0.4 \frac{\lambda}{B_1} \simeq 0.08$ arcsec.

Ex: 4.10: 3 apertures interferometer

1. $P(x, y) = e^{i\phi} \delta(x, y) + \delta(x \pm B, y)$. (NB: for dimensional reasons, there should be constants in factor of the δ , they have been neglected here)
2. We first calculate $\hat{P}(u, v) = e^{i\phi} + 2 \cos(2\pi uB)$. Then we obtain

$$S(\alpha, \beta) = \left| \hat{P} \left(\frac{\alpha}{\lambda}, \frac{\beta}{\lambda} \right) \right|^2 = 1 + 4 \cos \left(\frac{2\pi B\alpha}{\lambda} \right)^2 + 4 \cos \phi \cos \left(\frac{2\pi B\alpha}{\lambda} \right)$$

3. $T(u, v)$ is the Fourier Transform of $S(\alpha, \beta)$:

$$T(u, v) = 3\delta(u, v) + 2 \cos \phi \delta \left(u \pm \frac{B}{\lambda}, v \right) + \delta \left(u \pm \frac{2B}{\lambda}, v \right)$$

4. Case $\phi = 0$.

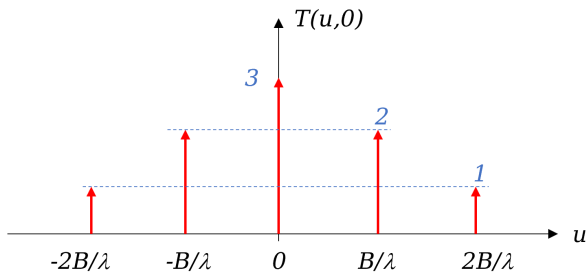

5 angular frequencies are seen by the interferometer: $(0, 0)$, $(\pm \frac{B}{\lambda}, 0)$ and $(\pm \frac{2B}{\lambda}, 0)$

5. Case $\phi = \pi/2$.

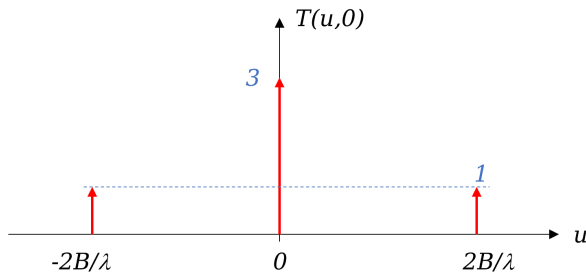

Now, only 3 angular frequencies are seen by the interferometer: $(0, 0)$ and $(\pm \frac{2B}{\lambda}, 0)$. The phase shift has made the term corresponding to frequencies $(\pm \frac{B}{\lambda}, 0)$ disappear (it is multiplied by zero).

6. We assume that $\phi = \pi/2$. The object observed is a circular disc of intensity A and angular diameter θ_0

(a) $I_0(\alpha, \beta) = A\Pi\left(\frac{\theta}{\theta_0}\right)$

(b) Start with $\hat{I}(u, v) = Cte \hat{I}_0(-u, -v) \cdot T(u, v)$, with $\hat{I}_0(-u, -v) = A \frac{\pi\theta_0^2}{2} \text{jinc}(\pi\theta_0 q)$ ($q = \sqrt{u^2 + v^2}$). We obtain

$$I(\alpha, \beta) = Cte \left(1 + \frac{4}{3} \text{jinc}\left(\frac{2\pi B\theta_0}{\lambda}\right) \cos\left(\frac{4\pi B\alpha}{\lambda}\right) \right)$$

(c) Contrast $C = \left| \frac{4}{3} \text{jinc}\left(\frac{2\pi B\theta_0}{\lambda}\right) \right|$

(d) The lowest value of B for which the contrast is 0 is $0.61 \frac{\lambda}{\theta_0}$